



High Efficiency High Voltage 3A Step Down Converter

1 Features

- Wide 4.5V to 18V Input Voltage Range
- 3A Constant Output Current
- 250uA Low I_Q
- 0.8V Reference Voltage
- Integrated 80mΩ / 45mΩ MOSFETs
- 800KHz Switching Frequency
- Internal Soft-Start
- Pulse Frequency Mode at Light Load
- Cycle-by-Cycle Current Limit
- Hiccup Short Circuit Protection
- Thermal Shutdown Protection
- Available in SOT563/SOT23-6 Package
- RoHS Compliant and Halogen-Free

2 Applications

- Security Cameras
- Flat Panels and Monitors
- Set Top Boxes and Media Players
- General Purpose

3 Description

The SC1300 is a high efficiency synchronous step-down switching converter. The device operates from an input voltage from 4.5V up to 18V. The main switch and synchronous switch are integrated in the device with very low R_{DS_ON} and capable of delivering up to 3A current.

The switching frequency is set at 800kHz to minimize output voltage ripple. Fault protection includes under voltage lockout, cycle-by-cycle current limit and thermal shutdown.

The SC1300 is available with space saving SOT563 and SOT23-6 package and requires minimal number of external components. Together with its low quiescent current, the SC1300 is ideal for security cameras, flat panels and monitors, digital set top boxes etc.

Device Information¹

PART NUMBER	PACKAGE	BODY SIZE (NOM)
SC1300	SOT563	1.60mm x 1.60mm
SC1300	SOT23-6	2.92mm x 2.80mm

1. For packaging details, see [Package Information](#) section.

Simplified Application Schematic

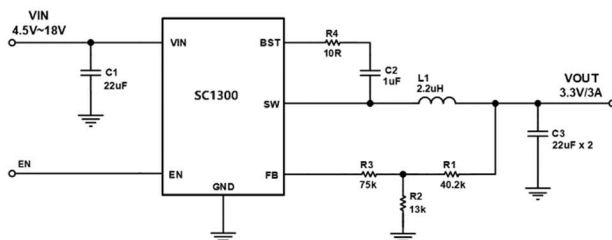

3.3V Output Efficiency

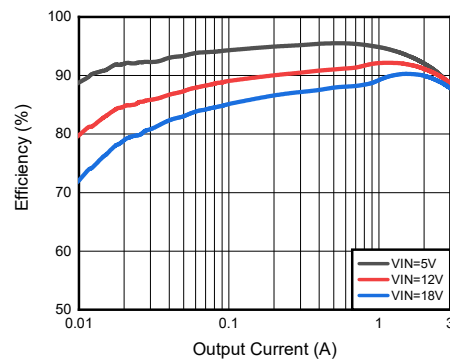



Table of Contents

1	Features	1
2	Applications	1
3	Description	1
	Table of Contents	2
4	Device Overview	3
4.1	Pinout and Pin Assignment	3
4.2	Pin Description	3
5	Parameter Information	4
5.1	Absolute Maximum Ratings	4
5.2	Recommended Operation Conditions	4
5.3	Electrical Sensitivity	4
5.4	Thermal Resistance	5
5.5	Electrical Characteristics	5
5.6	Typical Characteristics	7
6	Functional Description	9
6.1	Block Diagram	9
6.2	Operation	9
6.3	Device Mode Description	11
7	Application Information	12
7.1	Typical Application Circuit	12
7.2	Design Example	12
7.3	Detailed Design Description	13
7.4	Power Dissipation	15
7.5	Typical Application Curves	16
8	Layout Guidelines and Example	20
9	Package Information	21
9.1	Outline Dimensions	21
9.2	Recommended Land Pattern	25
10	Ordering Information	27



4 Device Overview

4.1 Pinout and Pin Assignment

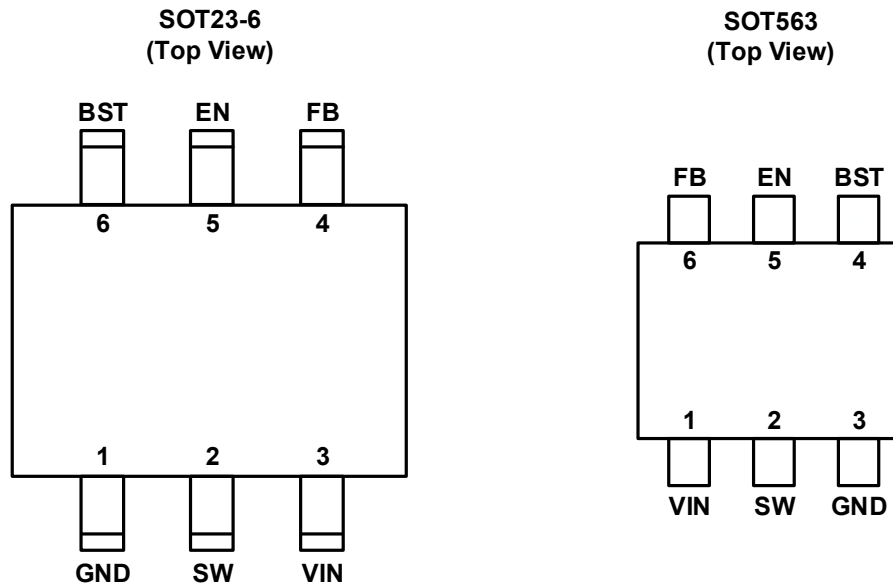

4.2 Pin Description

NAME	PIN NUMBER		PIN TYPE ¹	FUNCTION
	SOT563	SOT23-6		
VIN	1	3	P	Power supply voltage. Operates from a 4.5V to 18V input rail. A decoupling capacitor is required to decouple the input.
SW	2	2	O	Switch output. Switch pin connected to the internal MOSFET switches and inductor terminal.
GND	3	3	G	Power ground.
BST	4	6	O	Bootstrap. Connect a BST capacitor and a resistor between SW and BST to form a floating supply across the high-side switch driver.
EN	5	5	I	Enable. Pull high to enable the output.
FB	6	4	I	Feedback. Feedback pin for the internal control loop. Connect this pin to the external feedback divider.

1. I = Input, P = Power, G = Ground.



5 Parameter Information

5.1 Absolute Maximum Ratings

Exceeding the operating temperature range(unless otherwise noted)¹

SYMBOL	PARAMETER	MIN	MAX	UNIT
V _{IN}	Input voltage	-0.3	20	V
V _{EN}	Enable pin	-0.3	6.0	V
V _{BST}	Bootstrap voltage	-0.3	25	V
	Bootstrap(vs SW)	-0.3	6.5	V
V _{SW}	Switching node voltage	-0.3	20	V
	Switching node voltage(10ns transient)	-3	22	V
V _{FB}	Feedback pin	-0.3	6.5	V
T _J	Operating junction temperature	-40	150	°C
T _{stg}	Storage temperature	-65	150	°C

1. The maximum ratings are the limits to which the device can be subjected without permanently damaging the device. Note that the device is not guaranteed to operate properly at the maximum ratings. Exposure to the absolute maximum rating conditions for extended periods may affect device reliability.

5.2 Recommended Operation Conditions

SYMBOL ^{1,2}	PARAMETER	MIN	TYP	MAX	UNIT
V _{IN}	Input voltage	4.5		18	V
V _{OUT}	Output voltage	0.8		V _{IN} * D _{MAX}	V
I _{OUT}	Output current	0		3	A
V _{IO}	I/O pin voltage(EN, FB)	0		5.5	V
T _J	Operating junction temperature	-40		125	°C

1. The device is not guaranteed to function outside of its operating conditions.
2. Refer to the [Application Information](#) section for further information.

5.3 Electrical Sensitivity

SYMBOL	CONDITIONS	VALUE	UNIT
V _{ESD(HBM)}	Human-body model (HBM), ANSI/ESDA/JEDEC JS-001-2017 ¹	±2000	V
V _{ESD(CDM)}	Charge-device model (CDM), ANSI/ESDA/JEDEC JS-002-2022 ²	±500	V

1. JEDEC document JEP155 states that 500-V HBM allows safe manufacturing with a standard ESD control process.
2. JEDEC document JEP157 states that 250-V CDM allows safe manufacturing with a standard ESD control process.



5.4 Thermal Resistance

SYMBOL ¹	CONDITIONS	SOT563	SOT23-6	UNIT
Θ_{JA}	Natural convection, 2S2P PCB	88.8	117.71	°C/W
Θ_{JB}	Cold plate, 2S2P PCB	28.3	59.55	°C/W
Θ_{JC}	Cold plate, 2S2P PCB	55.6	34.00	°C/W
Ψ_{JB}	Natural convection, 2S2P PCB		59.46	°C/W
Ψ_{JT}	Natural convection, 2S2P PCB		2.27	°C/W

1. Thermal characteristics are based on simulation, and meet JEDEC document JESD51-7.

5.5 Electrical Characteristics

$V_{IN} = 12V$, $T_J = 25^\circ C$, unless otherwise noted.

SYMBOL	PARAMETER	CONDITIONS	MIN	TYP	MAX	UNIT
POWER SUPPLY						
I_Q	Quiescent current	No switching		250	300	μA
I_{SHDN}	Shutdown current	$V_{EN} = 0V$			10	μA
T_{ON_DLY}	Turn on delay time	$V_{IN} > V_{UVLO}$ to SW start		0.5		ms
T_{SS}	Soft-start time			2		ms
V_{UVLO}	Under voltage lockout	V_{IN} rising		4		V
V_{UVLO_HYS}	Under voltage lockout hysteresis			300		mV
ENABLE						
V_{EN_RISE}	Rising enable threshold			1.23		V
V_{EN_FALL}	Falling enable threshold			1.09		V
R_{PD}	EN pull down resistor			1		M Ω
VOLTAGE REFERENCE						
V_{FB}	Feedback voltage	$V_{IN} = 4.5$ to $18V$, $T_J = 25^\circ C$	0.792	0.8	0.808	V
I_{FB}	Feedback leakage current	$V_{FB} = V_{IN}$			100	nA
INTEGRATED POWER MOSFETS						
$R_{DS(on)}$	High-side FET on resistance			80		m Ω
	Low-side FET on resistance			45		m Ω
SWITCHING REGULATOR						
F_{SW}	Switching frequency	$V_{FB} = 0.75V$	600	800	1000	KHz
I_{SW}	Switch node leakage current	$V_{EN} = 0V$, $V_{IN} = 12V$			10	μA
T_{ON_MIN}	Minimum on time ¹			50		nS
T_{OFF_MIN}	Minimum off time ¹			180		nS
I_{ZCD}	Zero-current detection	$V_{OUT} = 3.3V$, $L_o = 2.2\mu H$, $I_{OUT} = 0A$		0		mA
CURRENT LIMIT						
I_{LIM}	Valley current limit ¹			4.5		A



Electrical Characteristics

$V_{IN} = 12V$, $T_J = 25^{\circ}C$, unless otherwise noted.

SYMBOL	PARAMETER	CONDITIONS	MIN	TYP	MAX	UNIT
THERMAL SHUTDOWN						
T_{TSD}	Thermal shutdown temperature ¹			160		$^{\circ}C$
T_{HYS}	Thermal shutdown hysteresis ¹			20		$^{\circ}C$

1. Guaranteed by design and engineering sample characterization.



5.6 Typical Characteristics

$V_{IN} = 12V$, $V_{OUT} = 3.3V$, $L = 2.2\mu H$, $T_A = 25^\circ C$, unless otherwise noted.

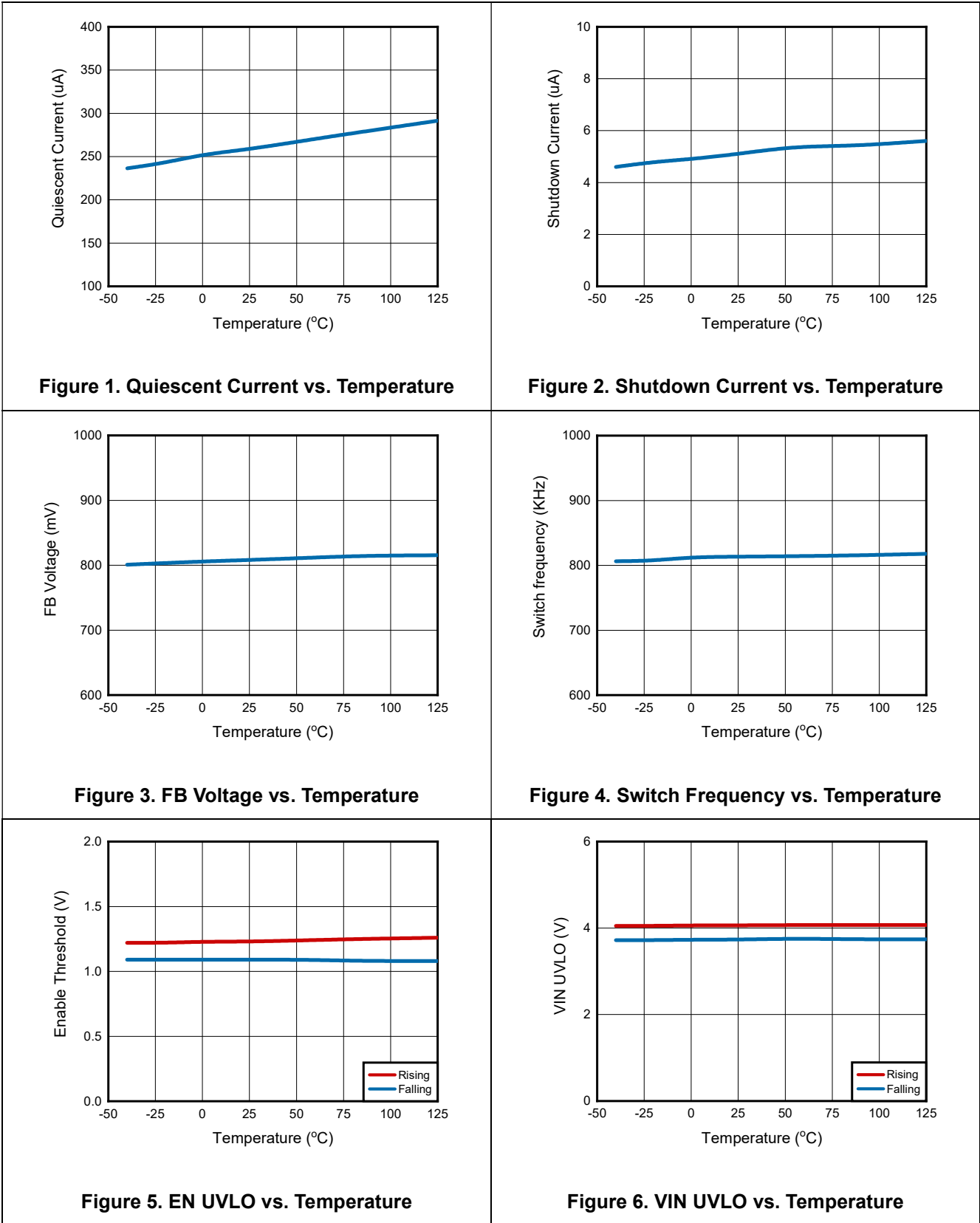



Typical Characteristics (continued)

$V_{IN} = 12V$, $V_{OUT} = 3.3V$, $L = 2.2\mu H$, $T_A = 25^\circ C$, unless otherwise noted.

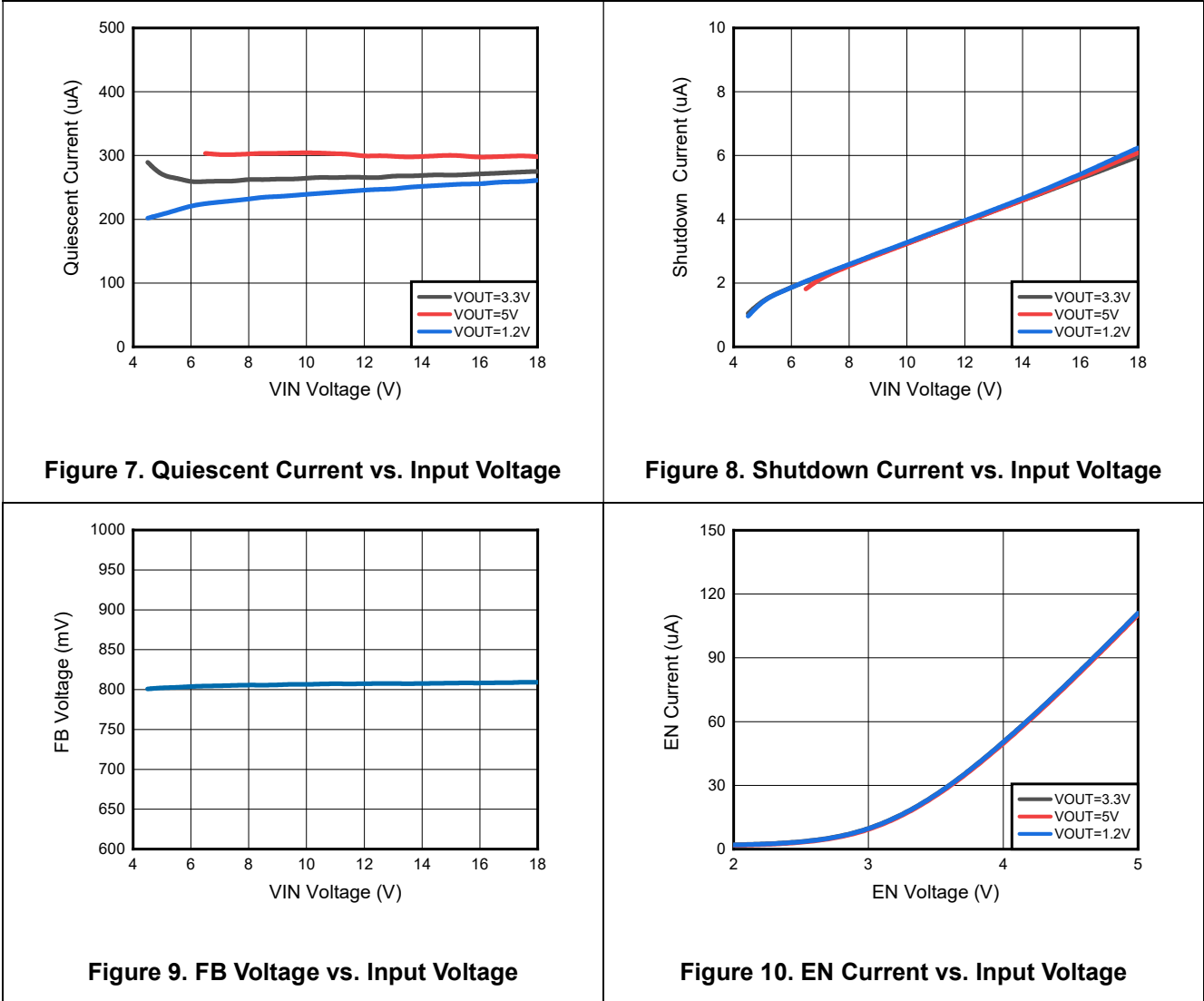



6 Functional Description

6.1 Block Diagram

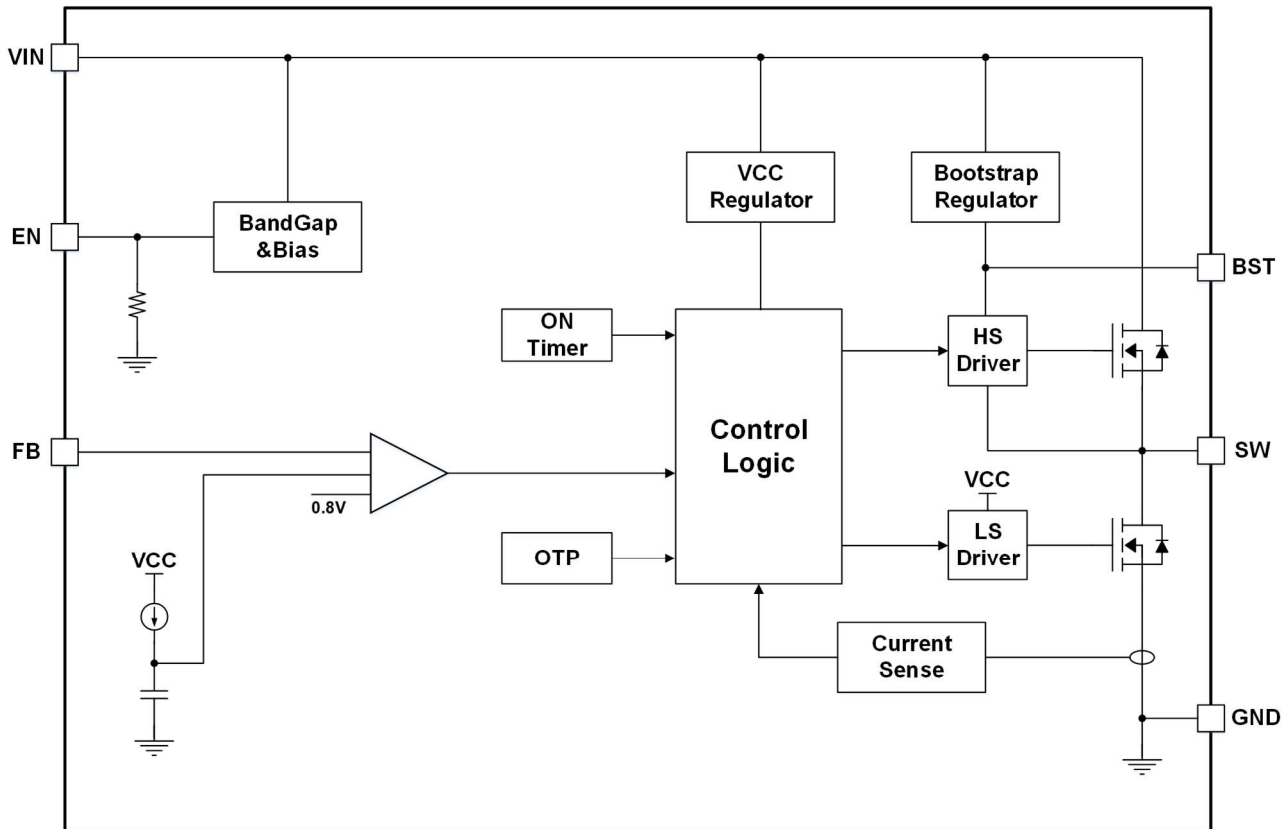

Figure 11. SC1300 Functional Block Diagram

6.2 Operation

The SC1300 is a synchronous switching DC/DC converter with constant on-time control. The adaptive on-time is so controlled by the input/output voltage that the IC operates at relative constant frequency, typically 800kHz. It is capable of delivering up to 3A for V_{IN} between 4.5V and 18V. The output voltage can be as low as 0.8V.

6.2.1 Constant On-Time Control

Based on the V_{OUT}/V_{IN} ratio, a simple circuit sets the required on time for the high-side MOSFET. It makes the switching frequency relatively constant regardless of the variation of input voltage, output voltage, and load current. The relation between t_{ON} and V_{IN} and V_{OUT} is defined as following [Equation\(1\)](#):

$$t_{ON} = \frac{V_{OUT}}{V_{IN}} \times 1.25\mu S \quad (1)$$

Excellent load transient response is achieved with a unique fast response constant on-time valley current mode. The switching frequency changes during load transition so that the output voltage comes back in regulation faster than a traditional fixed PWM control scheme. Internal loop compensation is integrated which simplifies the design process while minimizing the number of external components.



6.2.2 Pulse Frequency Modulation

The SC1300 automatically operates with pulse frequency modulation (PFM) at light load currents. As the output current decreases, the SC1300 reduces the switching frequency to maintain high efficiency. When the inductor current reaches zero, the low-side MOSFET turns off. Then the output capacitors offer power for load and feedback resistors.

When feedback voltage (V_{FB}) drops below the reference voltage, the high-side MOSFET is turned on. As the output current increases, the time period that the current modulator regulates becomes shorter, and the high-side MOSFET turns on more frequently. The switching frequency increases in turn. The output current reaches critical levels when the current modulator time is zero, and can be determined with the following [Equation\(2\)](#):

$$I_{OUT} = \frac{(V_{IN} - V_{OUT}) \times V_{OUT}}{2 \times L \times f_{SW} \times V_{IN}} \quad (2)$$

6.2.3 Soft Startup

After enabling the device, internal soft-start circuitry monotonically ramps up the output voltage which reaches nominal output voltage during a soft-start time of 2ms (typical). This avoids excessive inrush current and creates a smooth output voltage rise slope.

6.2.4 Pre-Bias Startup

The SC1300 is designed for monotonic start-up into pre-biased loads. If the output is pre-biased to a certain voltage during start-up, the BST voltage is refreshed and charged, and the voltage on the soft start is charged as well. If the BST voltage exceeds its rising threshold voltage, and the soft-start voltage exceeds the sensed output voltage at FB, the part works normally.

6.2.5 Bootstrap Charging

An external bootstrap capacitor can supply the high-side MOSFET driver. This high-side driver has its own UVLO protection. The rising threshold is 2.2V(typical) and a hysteresis is 150mV(typical). V_{IN} regulates the bootstrap capacitor voltage through a diode. The bootstrap regulator maintains a 4.5V(typical) voltage across BST-SW.

6.2.6 Under Voltage Lockout

To avoid mis-operation of the device at low input voltages, the SC1300 shuts down at voltages lower than 4V(typical) with hysteresis 300mV(typical).

6.2.7 Short Circuit Protection

The device provides short circuit protection function to prevent the device damaged from short condition. When the short condition occurs and the feedback voltage drops lower than 40% of the regulation level, the oscillator frequency will be reduced and hiccup mode will be triggered to prevent the device from overheating during the extended short condition. Once the short condition is removed, the frequency and current limit will return to normal.

6.2.8 Over Current Protection



The device has a 4.5A(typical) valley current limit control. While the low-side MOSFET is turned on, the conduction current is monitored by the internal circuitry. During over current protection(OCP) mode, the inductor valley current is exceeded the low-side source current limit, the high-side MOSFET does not turn on and the low-side MOSFET stays on for the next cycle. The high-side MOSFET turns on again when the inductor valley current is below the low-side sourcing current-limit at the start of a cycle.

6.2.9 Short Circuit Protection

The SC1300 enters short-circuit protection mode when it reaches the current limit and attempts to recover with hiccup mode. In this process, the SC1300 disables the output power stage, discharges the soft-start capacitor, and then attempts to soft-start again automatically. If the short-circuit condition remains after the soft-start ends, the SC1300 repeats this cycle until the short-circuit disappears and the output rises back to regulation level, the hiccup time typically 6ms.

6.2.10 Thermal Shutdown

The internal thermal shutdown circuitry forces the device to stop switching if the junction temperature exceeds 160°C(typical), both the high-side and low-side FETs are turned off. Once the device temperature falls below the threshold with hysteresis 20°C (typical), the device returns to normal operation automatically.

6.3 Device Mode Description

6.3.1 Device Enable

The device EN pin provides digital control to turn ON/OFF the converter. When V_{EN} exceeds the threshold voltage, the regulator will start the soft start function. If V_{EN} is below the shutdown threshold voltage, the regulator will turn into the shutdown mode and the shutdown current will be smaller than 10 μ A. Leaving EN floating or pulling it down to ground disables the SC1300. There is an internal 1M Ω resistor from EN to ground.



7 Application Information

The SC1300 device is typically used as a step down converter, which convert an input voltage from 4.5V to 18V to fixed output voltage 3.3V.

7.1 Typical Application Circuit

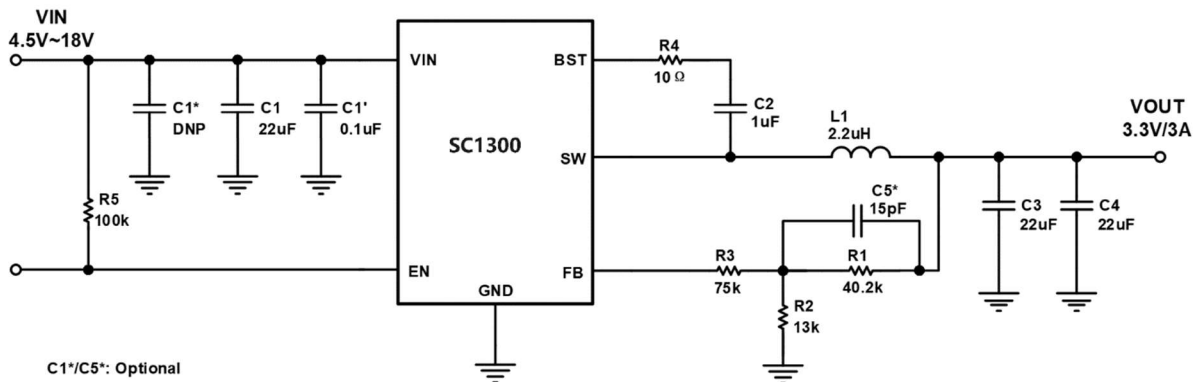

Figure 12. 3.3V, 3A Reference Design

7.2 Design Example

For this design example, use the parameters in [Table 1](#).

Table 1. Design Parameters

PARAMETER	EXAMPLE VALUE
Input Voltage	4.5V to 18V
Output Voltage	3.3V
Maximum Output Current	3A

[Table 2](#) lists the components used for the example.

Table 2. Design Example Component^{1,2}

COMPONENT	DESCRIPTION
C1,C3,C4	22uF, Ceramic Capacitor, 50V, X7R, size 0805
C2	1uF, Bootstrap Capacitor, 10V, X7R, size 0603
L1	2.2uH, Power Inductor
R1,R2,R3,R4	Divider resistor, 1%, size 0603
C5*	Optional, 15pF if it is needed

- The components used in these design cases do not belong to Steadichips products, Steadichips does not warrant its accuracy or completeness. Customers need to test and verify whether the selected components meet their intended use to ensure stable system operation.
- Refer to [Detailed Design Description](#) section for guidance on component selection and calculation equations.

7.3 Detailed Design Description

7.3.1 Output Voltage Setting

An external resistor divider is used to set output voltage according to [Equation\(3\)](#). By selecting R1 and R2, the output voltage is programmed to the desired value. When the output voltage is regulated, the typical voltage reference at the FB pin is 0.8V.

To ensure system performance, choose the value of R2 carefully. Since a large R2 make FB sensitive to noise and a small R2 increase power loss. So the value of 100KΩ is recommended. It can achieves a balance between system stability and low current consumption.

$$V_{OUT} = 0.8V \times \left(1 + \frac{R_1}{R_2}\right) \quad (3)$$

The feedback circuit is shown in [Figure 13](#).

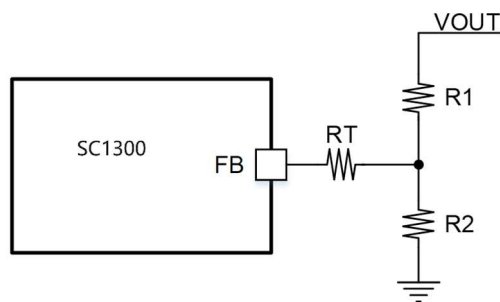

Figure 13. Feedback resistor divider

[Table 3](#) lists the recommended parameters values for common output voltages.

Table 3. Component selection for common output voltages

V _{OUT} (V)	R1(KΩ,1%)	R2(KΩ,1%)	RT(KΩ,1%)	L(uH)
5.0	40.2	7.68	75	3.3
3.3	40.2	13	75	2.2
2.5	40.2	19.1	100	2.2
1.8	40.2	32.4	110	1.5
1.5	40.2	45.3	147	1.5
1.2	40.2	82	147	1.0

7.3.2 Inductor Selection

The inductor selection trade-offs among size, cost, efficiency, and transient response requirements. Three key inductor parameters are specified for operation with the device: inductance value (L), inductor saturation current (ISAT), and DC resistance (DCR). In general, inductors with larger inductance and low DCR values provide much more output and high conversion efficiency, and smaller inductance values can give batter load transient response.

A good compromise between size and loss is to choose the peak-to-peak ripple current equals to 20% to 40% of the IC rated current. And the peak inductor current can be calculated by [Equation\(4\)](#) and [Equation\(5\)](#). Ensure that



the peak inductor current is below the maximum switch current.

$$\Delta I_L = (0.2 \text{ to } 0.4) \times I_{OUT(MAX)} \quad (4)$$

$$I_{L(peak)} = I_{OUT(MAX)} + \frac{\Delta I_L}{2} \quad (5)$$

The switching frequency, input voltage, output voltage, and selected inductor ripple current determines the inductor value according to Equation(6). Once an inductor value is chosen, the peak inductor current is determined by Equation(5). Attention that the inductor should not saturate under the inductor peak current.

$$L = \frac{(V_{IN} - V_{OUT}) \times V_{OUT}}{V_{IN} \times F_{SW} \times \Delta I_L} \quad (6)$$

7.3.3 Input Capacitor Selection

Input capacitance, C_{IN} , is needed to filter the pulsating current at the drain of the high-side power MOSFET. C_{IN} should be sized to do this without causing a large variation in input voltage. The input capacitance value determines the input voltage ripple of the converter. For most applications, a 10 μ F capacitor is sufficient.

The peak-to-peak voltage ripple on input capacitor can be estimated with Equation(7):

$$\Delta V_{IN} = \frac{I_{OUT}}{F_{SW} \times C_{IN}} \times \frac{V_{OUT}}{V_{IN}} \times \left(1 - \frac{V_{OUT}}{V_{IN}}\right) \quad (7)$$

For best performance, ceramic capacitors with X5R or X7R dielectrics are highly recommended because of their low ESR and small temperature coefficients. To compensate the derating of the ceramic capacitors, the voltage rating of capacitor should be twice of the maximum input voltage. The input capacitor also requires an adequate ripple current rating since it absorbs the input switching current.

The input ripple current can be estimated with Equation(8):

$$I_{CIN} = I_{OUT} \times \sqrt{D \times (1-D)} \quad (8)$$

Where D is the duty cycle of converter. The worst-case condition occurs at $V_{IN} = 2V_{OUT}$. At this point, the input ripple current of input capacitance is equal to half of output current. For simplification, choose an input capacitor with an RMS current rating greater than half of the maximum load current.

7.3.4 Output Capacitor Selection

The output capacitor stabilizes the DC output voltage, it directly affects the steady state, output voltage ripple, loop stability, and output voltage overshoot and undershoot during load current transient.

The output voltage ripple can be estimated with Equation(9):

$$\Delta V_{OUT} = \Delta I_L \times \left(C_{ESR} + \frac{1}{8 \times F_{SW} \times C_{OUT}} \right) \quad (9)$$

The output capacitor ripple is essentially composed of two part. One part is caused by the inductor ripple current



flowing through the ESR of output capacitors, another part is caused by the inductor ripple current charging and discharging output capacitors. For tantalum or electrolytic capacitors, the ESR dominates the impedance at the switching frequency. And when using ceramic capacitors, the capacitance dominates the impedance at the switching frequency and causes most of the output voltage ripple.

The output capacitance must be large enough to supply the current when a large load step occurs. But if the output capacitor value is too high, the output voltage will not be able to reach the design value during the soft start time. A 10uF Ceramic capacitors are recommended in this application.

7.4 Power Dissipation

For DC/DC, there is still some power deposited on the chip and converted into heat, in spite of switch mode power supplies have considerably higher efficiency when compared to linear regulators. The device power dissipation includes conduction loss, switching loss, gate charge loss and quiescent current losses. The maximum allowable continuous power dissipation at any ambient temperature is calculated by [Equation\(10\)](#):

$$P_{D(MAX)} = \frac{T_{J(MAX)} - T_A}{\theta_{JA}} \quad (10)$$

Where $T_{J(MAX)}$ is the maximum junction temperature, T_A is the ambient temperature and θ_{JA} is the junction to ambient thermal resistance. Once exceeding the maximum allowable power, The device enters thermal shutdown to avoid permanent damage.



7.5 Typical Application Curves

$V_{IN} = 12V$, $V_{OUT} = 3.3V$, $L = 2.2\mu H$, $T_A = 25^\circ C$, unless otherwise noted.

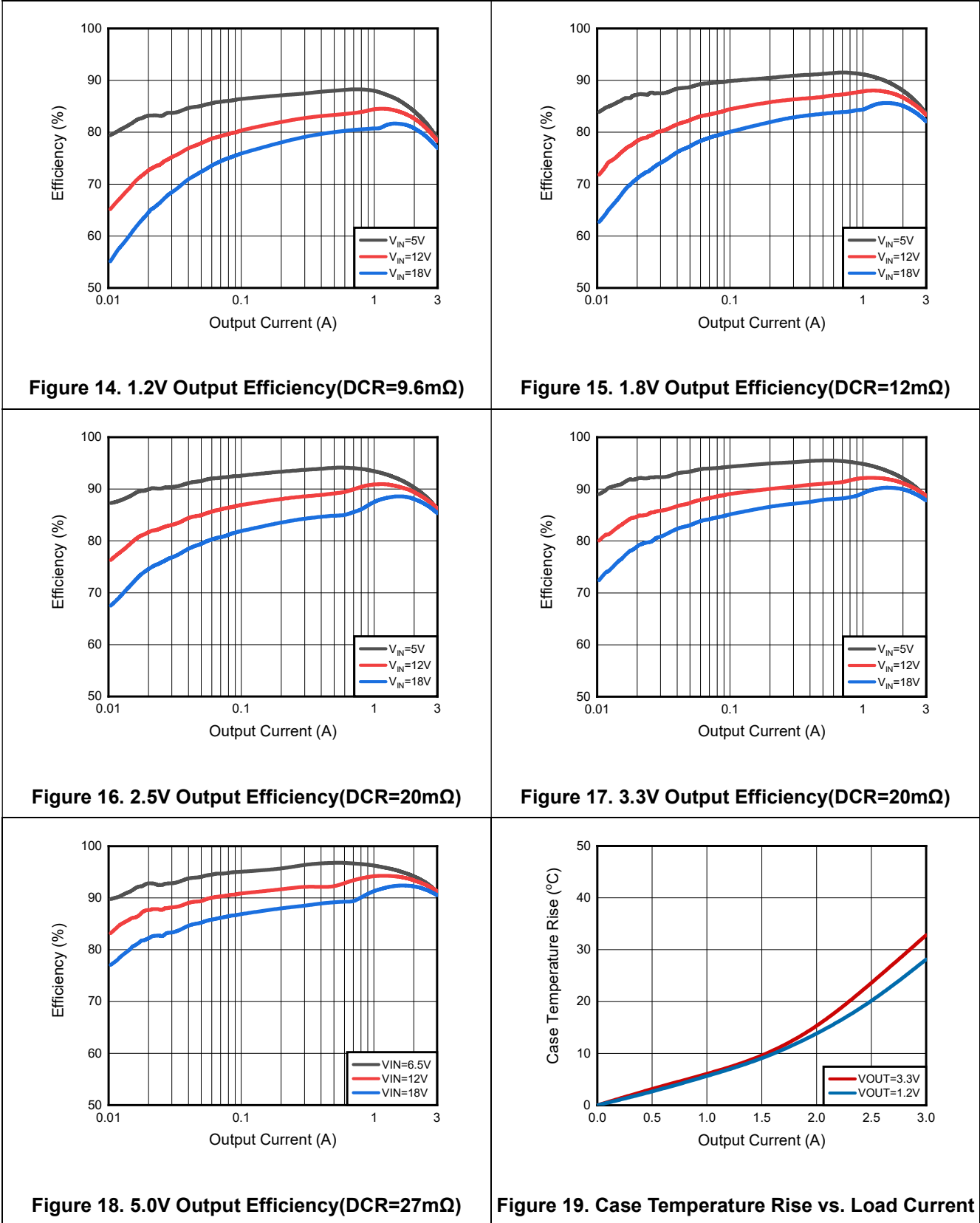



Typical Application Curves (continued)

$V_{IN} = 12V$, $V_{OUT} = 3.3V$, $L = 2.2\mu H$, $T_A = 25^\circ C$, unless otherwise noted.

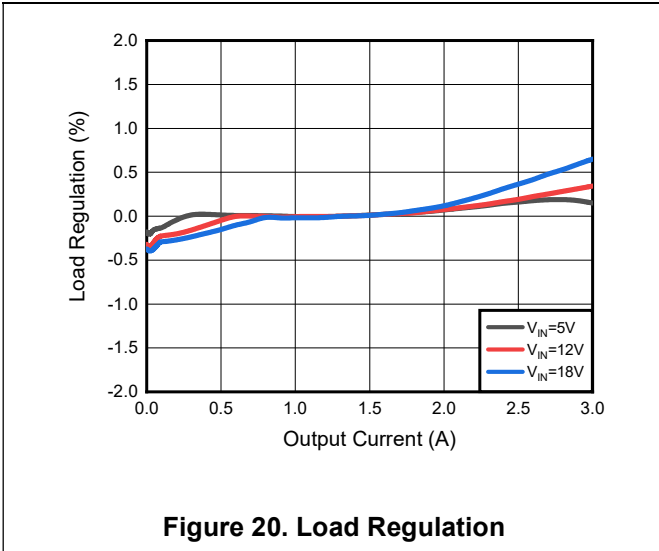

Figure 20. Load Regulation

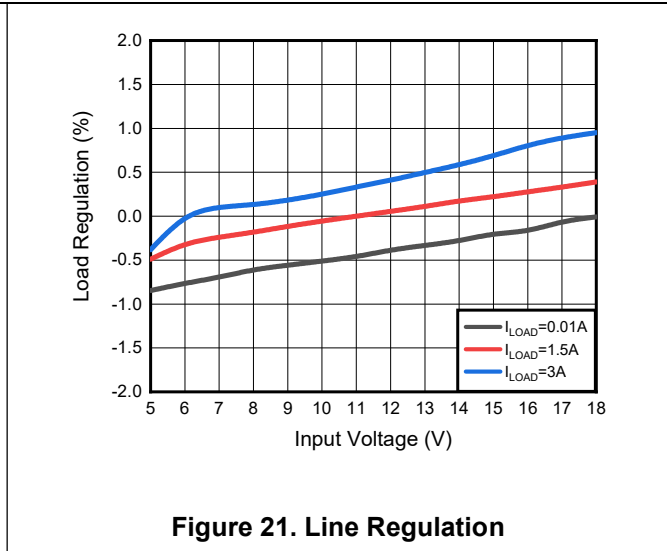

Figure 21. Line Regulation

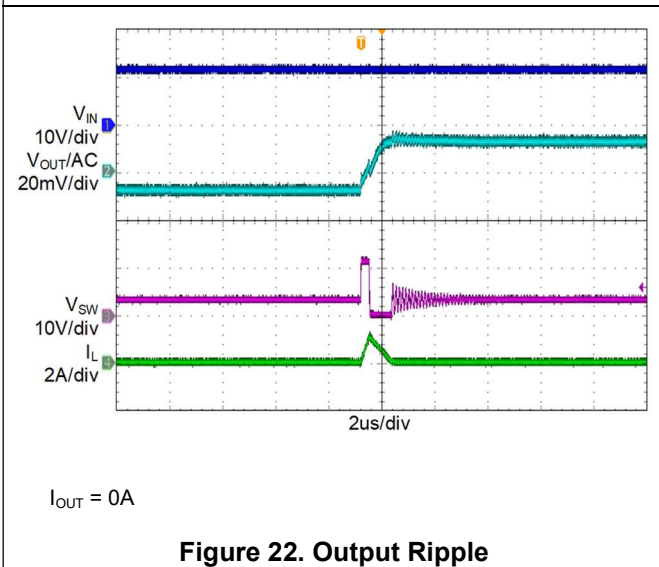

Figure 22. Output Ripple

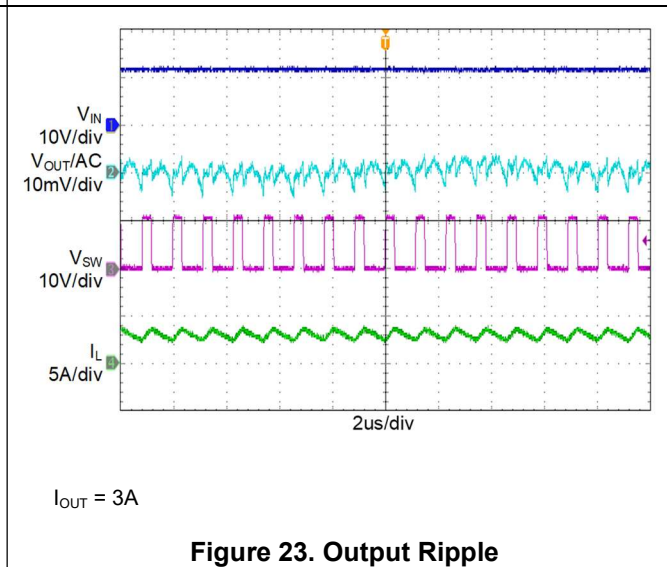

Figure 23. Output Ripple

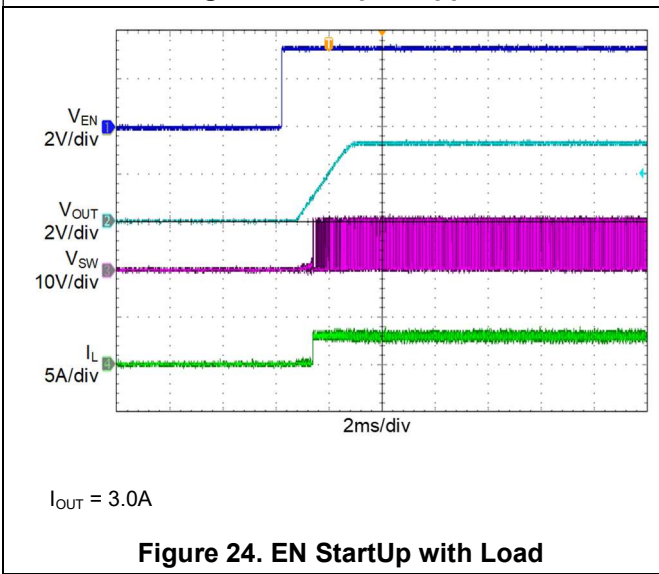

Figure 24. EN StartUp with Load

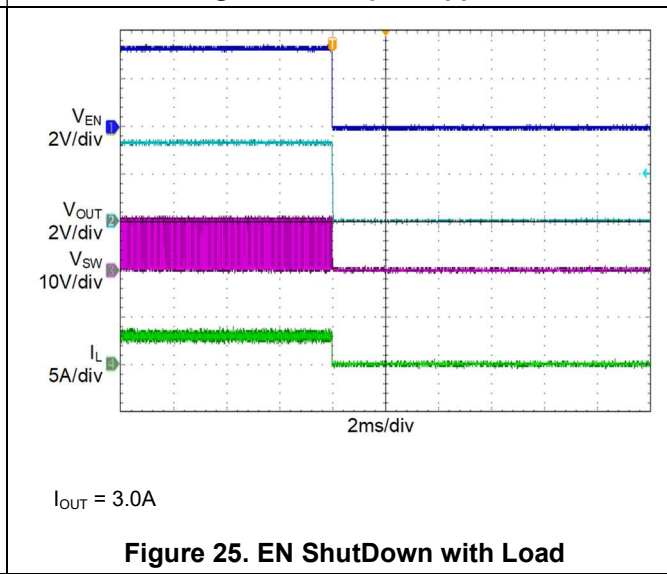
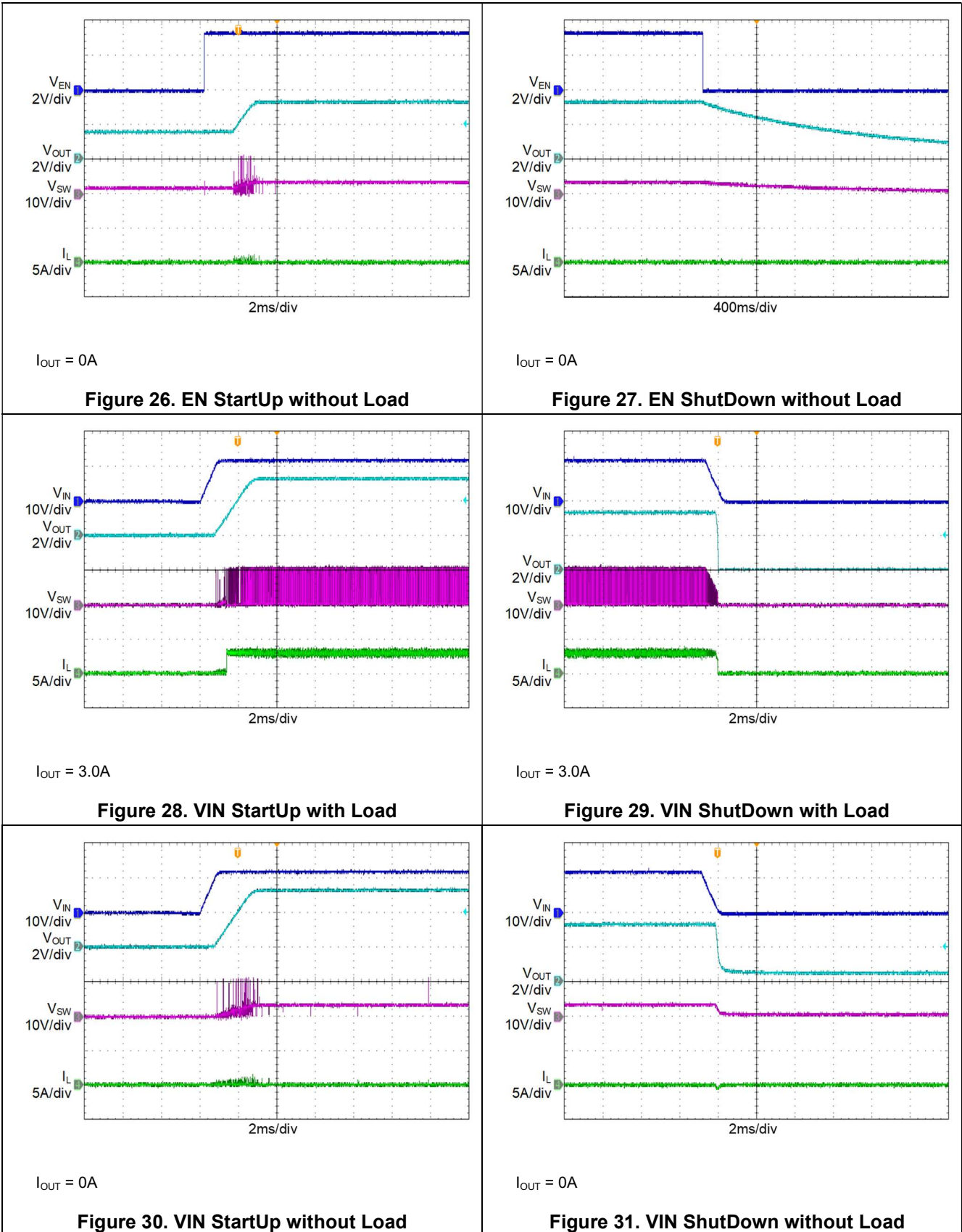

Figure 25. EN ShutDown with Load



Typical Application Curves (continued)

$V_{IN} = 12V$, $V_{OUT} = 3.3V$, $L = 2.2\mu H$, $T_A = 25^\circ C$, unless otherwise noted.





Typical Application Curves (continued)

$V_{IN} = 12V$, $V_{OUT} = 3.3V$, $L = 2.2\mu H$, $T_A = 25^\circ C$, unless otherwise noted.

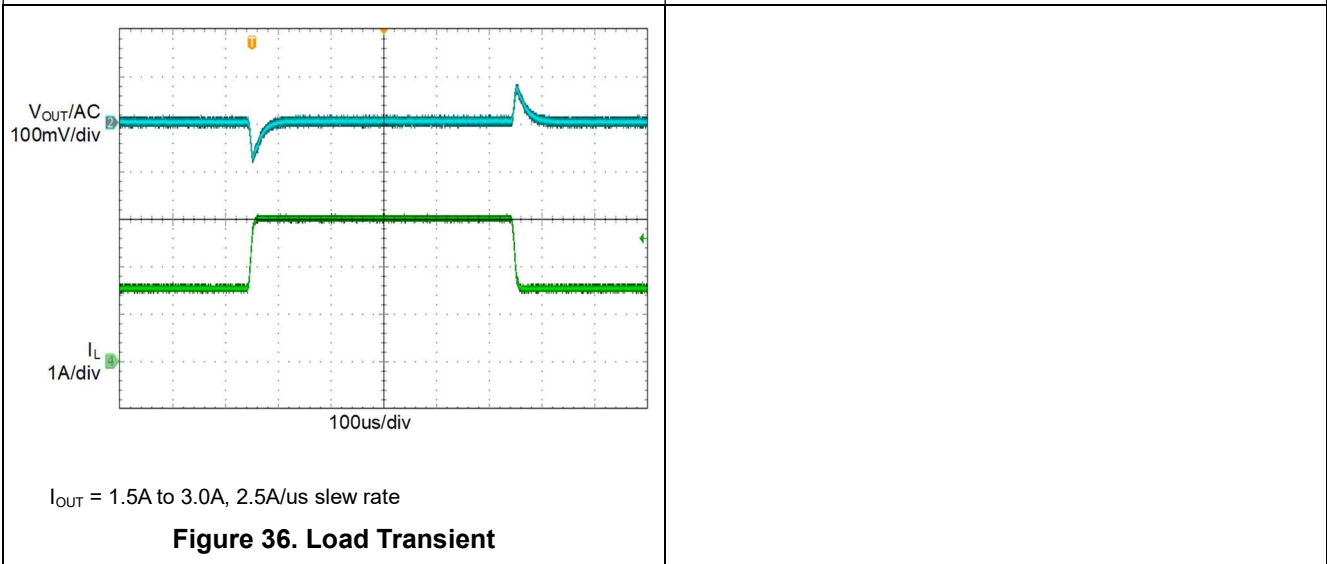
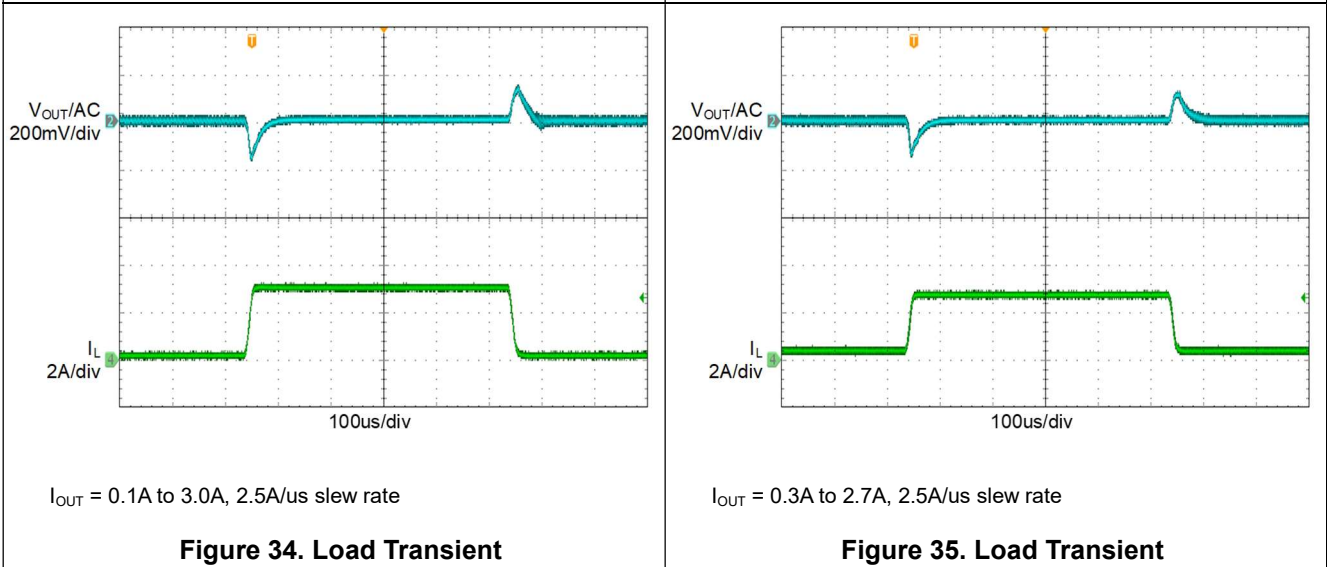
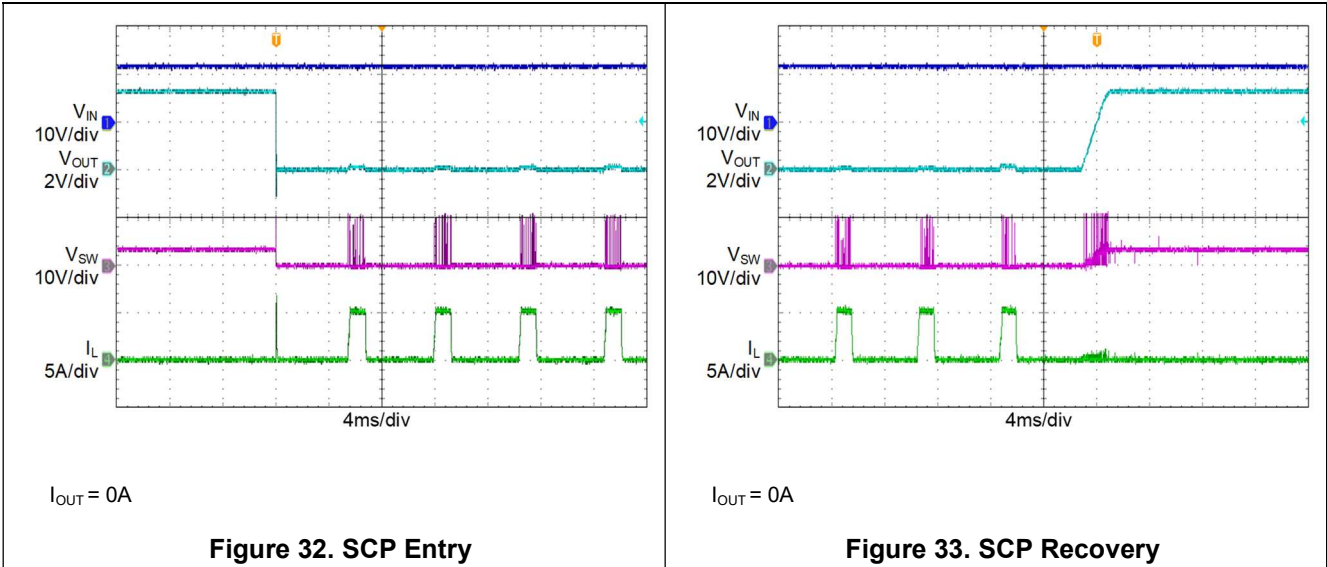



8 Layout Guidelines and Example

Efficient PCB layout is critical for stable operation. For the high-frequency switching converter, a poor layout design can result in poor line or load regulation and stability issues. For best results, follow the guidelines below.

- 1) Place the high-current paths (GND, IN, and SW) very close to the device with short, direct, and wide traces.
- 2) Place the input capacitor as close to IN and GND as possible.
- 3) Place the external feedback resistors next to FB.
- 4) Keep the switching node SW short and away from the feedback network.
- 5) Keep the VOUT sense line as short as possible or keep it away from the power inductor.

For best results, follow the layout example below.

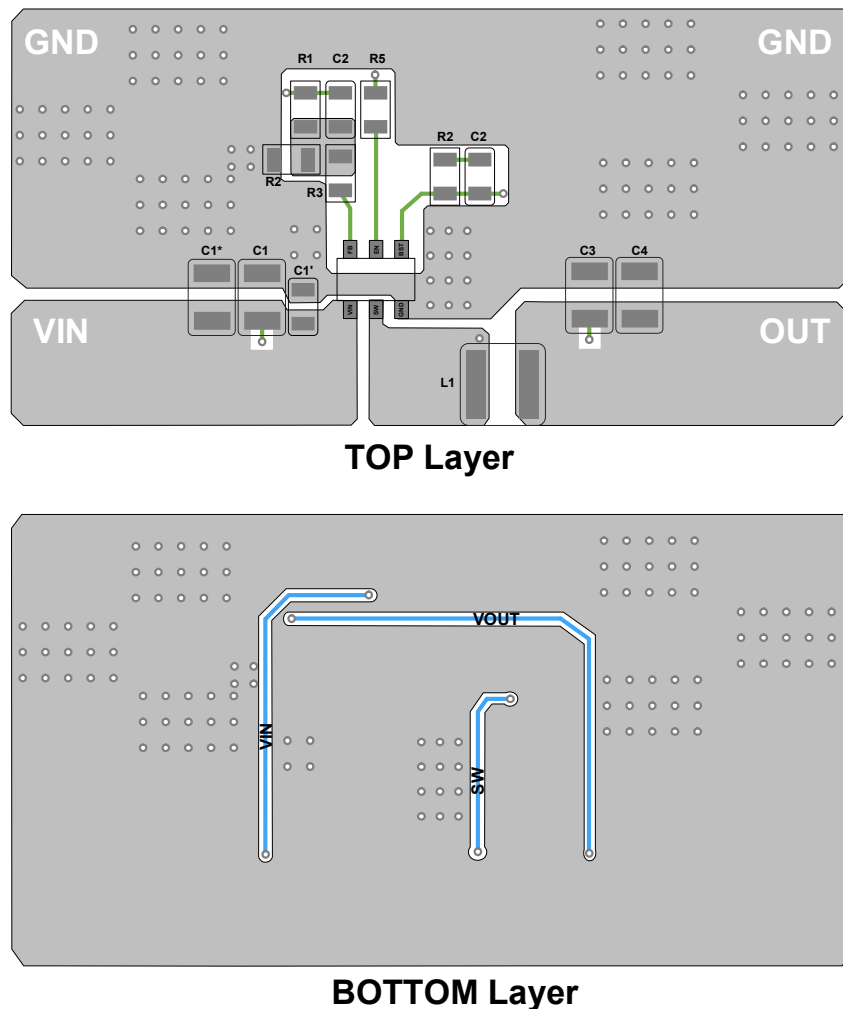
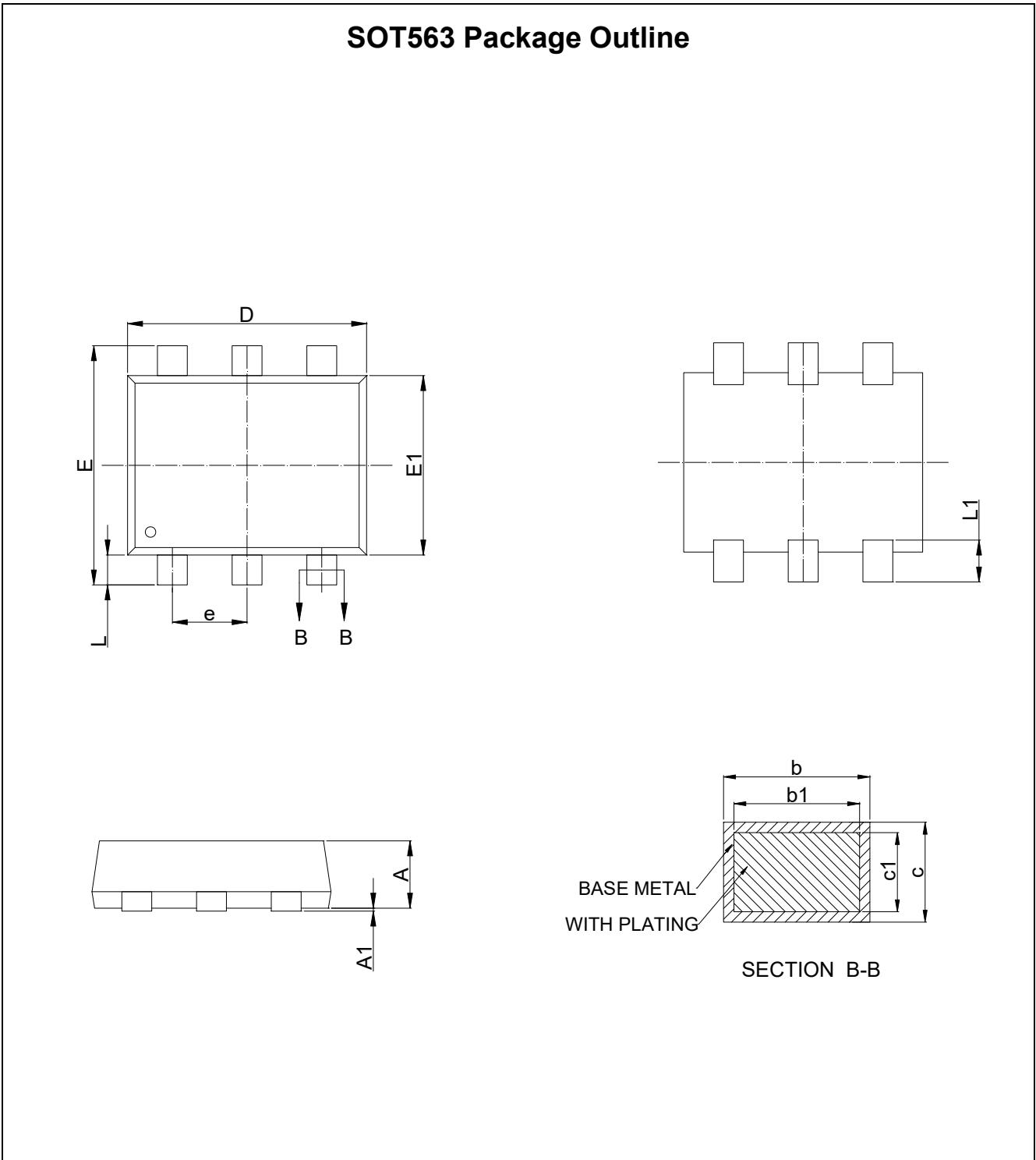

Figure 37. Typical SC1300 Example Layout



9 Package Information

9.1 Outline Dimensions



NOTES:

1. All dimensions are in millimeters.
2. Package dimensions does not include mold flash, protrusions, or gate burrs.
3. Refer to the [Table 4 SOT563 dimensions\(mm\)](#).

**Table 4. SOT563 dimensions(mm)**

SYMBOL	MIN	TYP	MAX
A	0.53		0.60
A1	0.00		0.05
b	0.19		0.27
b1	0.18	0.20	0.23
c	0.11		0.16
c1	0.10	0.11	0.12
D	1.50	1.60	1.70
E	1.503	1.60	1.70
E1	1.10	1.20	1.30
e	0.50BSC		
L	0.10	0.20	0.30
L1	0.20	0.30	0.40



SOT23-6 Package Outline

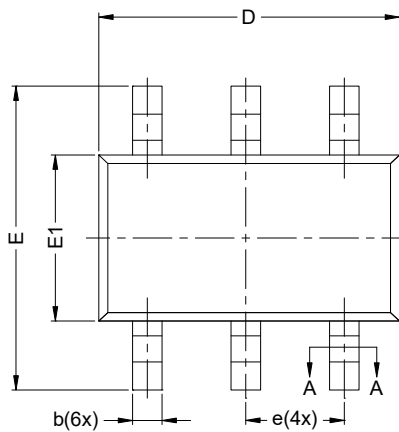

TOP VIEW

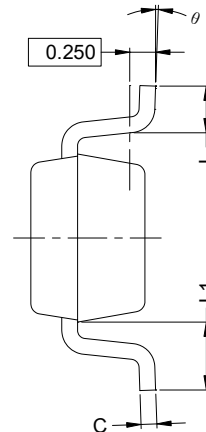

SIDE VIEW

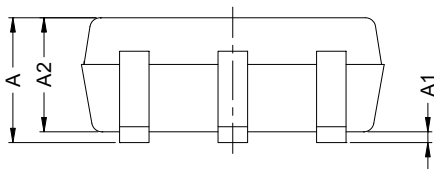

FRONT VIEW

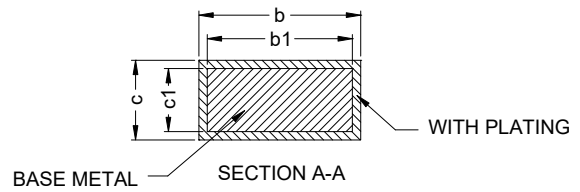

NOTES: (continued)

- 1. Refer to the [Table 5 SOT23-6 dimensions\(mm\)](#).

**Table 5. SOT23-6 dimensions(mm)**

SYMBOL	MIN	TYP	MAX
A			1.25
A1	0.04		0.10
A2	1.00	1.10	1.20
b	0.38		0.46
b1	0.37	0.40	0.43
c	0.13		0.17
c1	0.12	0.13	0.14
D	2.82	2.92	3.02
E	2.60	2.80	3.00
E1	1.50	1.60	1.70
e	0.95 BSC		
e1	1.90 BSC		
L	0.30		0.60
L1	0.60 REF		
θ	0°		8°



9.2 Recommended Land Pattern

SOT563 Land Pattern Example

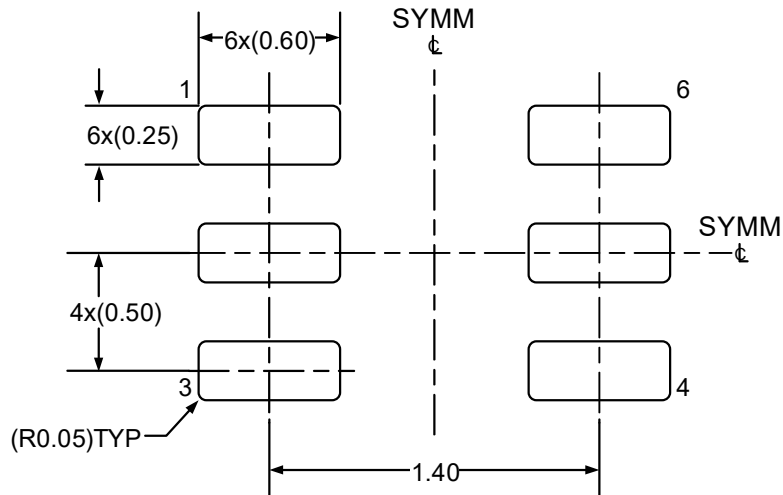

NOTES: (continued)

- 1. Refer to the IPC-7351 can also help you complete the designs.
- 2. Exposed metal shown.
- 3. Drawing is 30X scale.



SOT23-6 Land Pattern Example

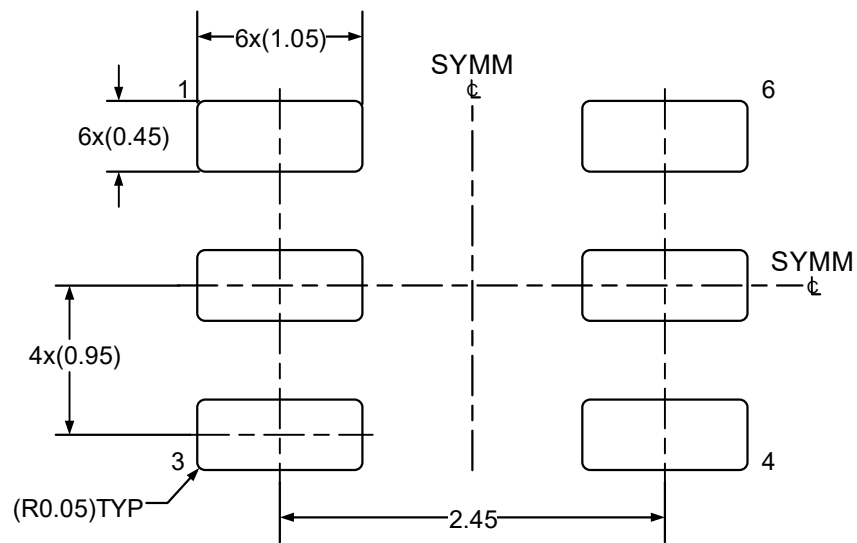

NOTES: (continued)

1. Refer to the IPC-7351 can also help you complete the designs.
2. Drawing is 20X scale.



10 Ordering Information

Ordering Code	Package Type	ECO Plan	Packing Type	MOQ	OP Temp(°C)
SC1300SOTR-I	SOT563	Green	Tape & Reel	5000	Industrial -40°C to +85°C
SC1300SSTR-I	SOT23-6	Green	Tape & Reel	3000	Industrial -40°C to +85°C