



2-Bit Bidirectional Voltage-Level Translator for Open-Drain and Push-Pull Applications

1. Feature

- ❑ No Direction-Control
- ❑ Data Rates
24Mbps (Push-Pull)
2Mbps (Open-Drain)
- ❑ 1.65V to 5.5V on A ports and 2.3V to 5.5V on B Ports ($V_{CCA} \leq V_{CCB}$)
- ❑ V_{CC} Isolation: If Either V_{CC} is at GND, Both Ports are in the High-Impedance State
- ❑ No Power-Supply Sequencing Required: Either V_{CCA} or V_{CCB} can be Ramped First
- ❑ I_{OFF} : Supports Partial-Power-Down Mode Operation
- ❑ Extended Temperature: -40°C to $+85^{\circ}\text{C}$
- ❑ Latch-Up Performance Exceeds 100 mA
- ❑ ESD Protection:
 - 4-kV Human-Body Model (HBM)
 - 2-kV Charged-Device Model (CDM)

2. Applications

- Handset
- Smartphone
- Tablet
- Desktop PC

3. General Description

It uses two separate configurable power-supply rails, with the A ports supporting operating voltages from 1.65V to 5.5V while it tracks the V_{CCA} supply, and the B ports supporting operating voltages from 2.3V to 5.5V while it tracks the V_{CCB} supply. This allows the support of both lower and higher logic signal levels while providing bidirectional translation capabilities between any of the 1.8V, 2.5V, 3.3V and 5V voltage nodes.

When the output-enable(OE) input is low, all outputs are placed in the high-impedance state.

The SC0102 is designed so that the OE input circuit is supplied by V_{CCA} .

To ensure the high-impedance state during power up or power down, OE should be tied to GND through a pull down resistor; the minimum value of the resistor is determined by the current-sourcing capability of the driver.

The SC0102 is available in MSOP8L_3x3_0.65, and TSOT23-8 packages. It operates over an ambient temperature range of -40°C to $+85^{\circ}\text{C}$

4. PACKAGE INFORMATION

PART NUMBER	PACKAGE	BODY SIZE
SC0102	TSOT23-8	2.9mm x 1.6mm
SC0102	MSOP-8	3mm x 3mm



infringements of patents or other rights of third parties which may result from its use. No license is granted by implication or otherwise under any patent or patent rights of StediChips

Functional Block Diagram

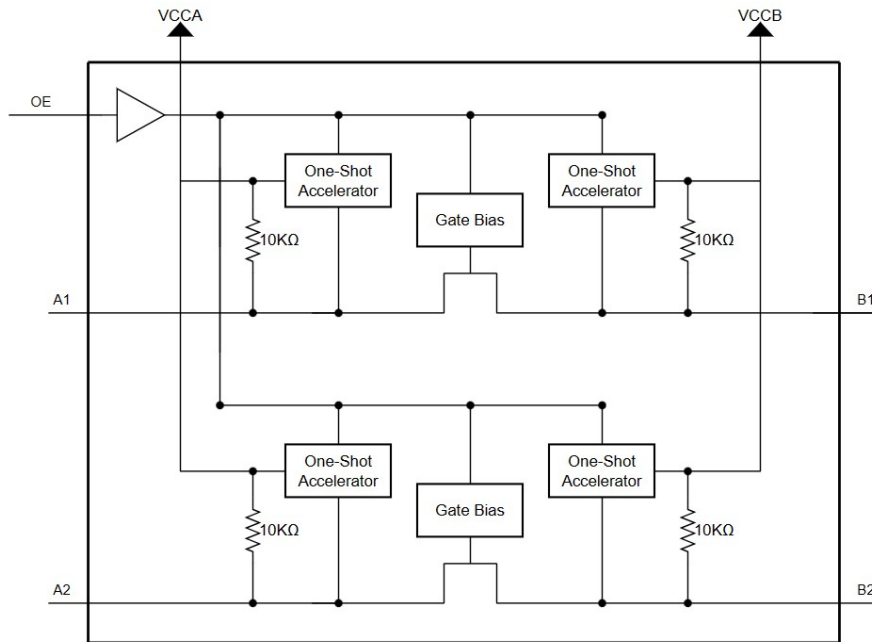
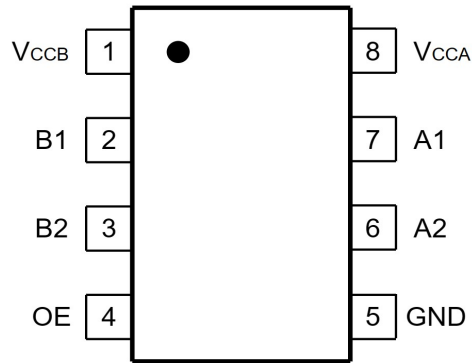

Figure 1.Block Diagram

5. PAD Definition



8-Pin TSOT23 Top View
Fig.2 Pad definition of SC0102

Pin Functions:TSOT23-8

Pin	Name	I/O	DESCRIPTION
1	VCCB	POWER	B-port supply voltage. $2.3\text{ V} \leq VCCB \leq 5.5\text{ V}$.
2	B1	I/O	Input/output B1. Reference to VCCB.
3	B2	I/O	Input/output B2. Reference to VCCB.
4	OE	Input	3-state output-mode enable. Pull OE low to place all outputs in 3-state mode. Referenced to VCCA.
5	GND	GROUND	Device ground.
6	A2	I/O	Input/output A2. Referenced to VCCA.
7	A1	I/O	Input/output A1. Referenced to VCCA.
8	VCCA	POWER	A-port supply voltage. $1.65\text{ V} \leq VCCA \leq 5.5\text{ V}$ and $VCCA \leq VCCB$.

PAD Definition

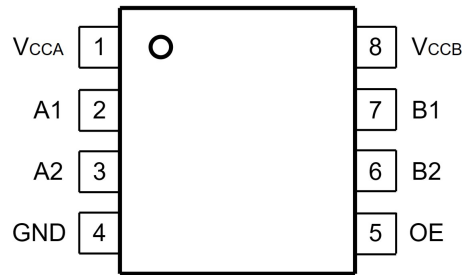

8-Pin MSOP Top View
Pad definition of SC0102

Pin Functions:MSOP-8

Pin	Name	I/O	DESCRIPTION
1	VCCA	POWER	A-port supply voltage. $1.65\text{ V} \leq V_{CCA} \leq 5.5\text{ V}$ and $V_{CCA} \leq V_{CCB}$.
2	A1	I/O	Input/output A1. Referenced to V_{CCA} .
3	A2	I/O	Input/output A2. Referenced to V_{CCA} .
4	GND	GROUND	Device ground.
5	OE	I	3-state output-mode enable. Pull OE low to place all outputs in 3-state mode. Referenced to V_{CCA} .
6	B2	I/O	Input/output B2. Reference to V_{CCB} .
7	B1	I/O	Input/output B1. Reference to V_{CCB} .
8	VCCB	POWER	B-port supply voltage. $2.3\text{ V} \leq V_{CCB} \leq 5.5\text{ V}$.

6. Specifications

6.1 Absolute Maximum Ratings

Over operating free-air temperature range (unless otherwise noted)⁽¹⁾

SYMBOL	PARAMETER	MIN	MAX	units	
VCCA	Supply Voltage Range	-0.3	6.0	V	
VCCB	Supply Voltage Range	-0.3	6.0	V	
V _I ⁽²⁾	Input Voltage Range	A port	-0.3	6.0	V
		B port	-0.3	6.0	
		OE	-0.3	6.0	
V _O ⁽²⁾	Voltage range applied to any output in the high impedance or power-off state	A port	-0.3	6.0	V
		B port	-0.3	6.0	
V _O ⁽²⁾⁽³⁾	Voltage range applied to any output in the high or low state	A port	-0.3	V _{CCA} +0.3	V
		B port	-0.3	V _{CCB} +0.3	
I _{IK}	Input clamp current	V _I <0		-50	mA
I _{OK}	Output clamp current	V _O <0		-25	mA
I _O	Continuous output current			±50	mA
	Continuous current through VCCA, VCCB or GND			±100	mA
T _J	Junction Temperature			150	°C
T _{stg}	Storage temperature	-60		150	°C

(1) Stresses beyond those listed under Absolute Maximum Ratings may cause permanent damage to the device. These are stress ratings only, and functional operation of the device at these or any other conditions beyond those indicated under Recommended Operating Conditions is not implied. Exposure to absolute-maximum-rated conditions for extended periods may affect device reliability.

(2) The input and output negative-voltage ratings may be exceeded if the input and output current ratings are observed.

(3) The value of VCCA and VCCB are provided in the recommended operating conditions table.

6.2 ESD Rating

Symbol	parameter	rating	units
V(ESD) Electrostatic discharge	Human-Body Model (HBM)	±4000	V
	Charged-Device Model (CDM)	±2000	V



6.3 Recommended Operating Conditions

VCCI is the supply voltage associated with the input port. VCCO is the supply voltage associated with the output port.

PARAMETER		VCCA	VCCB	MIN	MAX	UNIT
Supply voltage ⁽¹⁾	VCCA			1.65	5.5	V
	VCCB			2.3	5.5	
High-level input voltage (V _{IH})	A-port I/Os	1.65 V to 1.95 V	2.3 V to 5.5 V	VCCI – 0.2	VCCI	V
		2.3 V to 3.6 V		VCCI – 0.4	VCCI	
	B-port I/Os	1.65 V to 3.6 V	2.3 V to 5.5 V	VCCI – 0.4	VCCI	
	OE input	1.65 V to 3.6 V	2.3 V to 5.5 V	VCCI × 0.8	5.5	
Low-level input voltage (V _{IL})	A-port I/Os	1.65 V to 3.6 V	2.3 V to 5.5 V	0	0.15	V
	B-port I/Os	1.65 V to 3.6 V	2.3 V to 5.5 V	0	0.15	
	OE input	1.65 V to 3.6 V	2.3 V to 5.5 V	0	VCCI × 0.25	
Input transition rise or fall rate(Δt/Δv)		1.65 V to 3.6 V	2.3 V to 5.5 V		10	ns/V
		1.65 V to 3.6 V	2.3 V to 5.5 V		10	
		1.65 V to 3.6 V	2.3 V to 5.5 V		10	
T _A Operating free-air temperature				-40	85	°C

(1) VCCA must be less than or equal to VCCB.

(2) The maximum V_{IL} value is provided to ensure that a valid V_{OL} is maintained. The V_{OL} value is V_{IL} plus the voltage drop across the pass gate transistor.



6.4 Electrical Characteristics

over recommended operating free-air temperature range (unless otherwise noted) (1) (2) (3)

PARAMETER	CONDITIONS	V _{CCA}	V _{CCB}	TEMP	MIN	TYP	MAX	UNITS
V _{OH} _A	Port A output high voltage	I _{OH} = -20 μA V _{IB} ≥ V _{CCB} - 0.4V	1.65V to 5.5V	2.3V to 5.5V	Full	V _{CCA} × 0.8		V
V _{OL} _A	Port A output low voltage	I _{OL} = 1mA V _{IB} ≤ 0.15V	1.65V to 5.5V	2.3V to 5.5V	Full		0.4	
V _{OH} _B	Port B output high voltage	I _{OH} = -20 μA V _{IA} ≥ V _{CCA} - 0.4 V	1.65V to 5.5V	2.3V to 5.5V	Full	V _{CCB} × 0.8		
V _{OL} _B	Port B output low voltage	I _{OL} = 1mA V _{IA} ≤ 0.15 V	1.65V to 5.5V	2.3V to 5.5V	Full		0.4	
I _I	Input leakage current	OE	1.65V to 5.5V	2.3V to 5.5V	+25°C	-1	1	μA
					Full	-1.5	1.5	
I _{off}	Partial power down current	A Ports	0V	0V to 5.5V	+25°C	-0.5	0.5	μA
					Full	-1	1	
		B Ports	0V to 5.5V	0V	+25°C	-0.5	0.5	μA
					Full	-1	1	
I _{oz}	High-impedance State output current	A or B port OE=0V	1.65V to 5.5V	2.3V to 5.5V	+25°C	-1	1	μA
					Full	-1.5	1.5	
I _{CCA}	V _{CCA} supply current	V _I = V _O = open I _O = 0	1.65V to V _{CCB}	2.3V to 5.5V	+25°C		1.0	μA
			5.5V	0V	Full		1.0	
			0V	5.5V	Full		-1	
I _{CCB}	V _{CCB} supply current	V _I = V _O = open I _O = 0	1.65V to V _{CCB}	2.3V to 5.5V	+25°C	5	15	μA
			5.5V	0V	Full		-1	
			0V	5.5V	Full		1	
I _{CCA} + I _{CCB}	Combined supply current	V _I = V _{CCI} or GND I _O = 0	1.65V to V _{CCB}	2.3V to 5.5V	+25°C		16	μA
I _{CCZ} _A	V _{CCA} supply current	V _I = V _{CCI} or 0V I _O = 0, OE=0V	1.65V to V _{CCB}	2.3V to 5.5V	Full		1	μA
I _{CCZ} _B	V _{CCB} supply current	V _I = V _{CCB} or 0V I _O = 0, OE=0V	2.3V to 5.5V	2.3V to 5.5V	Full		1	μA
C _I	Input capacitance	OE	3.3V	3.3V	+25°C		2.5	pF
C _{IO}	Input-to-output internal capacitance	A port	3.3V	3.3V	+25°C		5	pF
		B port	3.3V	3.3V	+25°C		5	

(1) V_{CCI} is the VCC associated with the input port.

(2) V_{CCO} is the VCC associated with the output port.

(3) V_{CCA} must be less than or equal to V_{CCB}.

6.5 Timing Requiremen
VCCA=1.8V±0.15V

		V _{CCB} =2.5V ±0.2V	V _{CCB} =3.3V ±0.3V	V _{CCB} =5V ±0.5V	UNIT
		TYP	TYP	TYP	
Data rate	Push-pull driving	24	24	24	Mbps
	Open-drain driving	2	2	2	
Pulse duration(t _w)	Push-pull driving (data inputs)	41	41	41	ns
	Open-drain driving (data inputs)	500	500	500	

VCCA=2.5V±0.2V

		V _{CCB} =2.5V ±0.2V	V _{CCB} =3.3V ±0.3V	V _{CCB} =5V ±0.5V	UNIT
		TYP	TYP	TYP	
Data rate	Push-pull driving	24	24	24	Mbps
	Open-drain driving	2	2	2	
Pulse duration(t _w)	Push-pull driving (data inputs)	41	41	41	ns
	Open-drain driving (data inputs)	500	500	500	

VCCA=3.3V±0.3V

		V _{CCB} =3.3V ±0.3V	V _{CCB} =5V ±0.5V	UNIT
		TYP	TYP	
Data rate	Push-pull driving	24	24	Mbps
	Open-drain driving	2	2	
Pulse duration(t _w)	Push-pull driving (data inputs)	41	41	ns
	Open-drain driving (data inputs)	500	500	

VCCA=5V±0.5V

		V _{CCB} =5V ±0.5V	UNIT
		TYP	
Data rate	Push-pull driving	24	Mbps
	Open-drain driving	2	
Pulse duration(t _w)	Push-pull driving (data inputs)	41	ns
	Open-drain driving (data inputs)	500	



6.6 Switching Characteristics: $V_{CCA}=1.8V\pm 0.15V$

over recommended operating free-air temperature range, $V_{CCA} = 1.8 V \pm 0.15 V$ (unless otherwise noted)

PARAMETER		TEST CONDITIONS		MIN	MAX	UNIT	
t _{PHL}	Propagation delay time (high-to-low output)	A-to-B	Push-pull driving	$V_{CCB} = 2.5 V \pm 0.2 V$	4.6		ns
				$V_{CCB} = 3.3 V \pm 0.3 V$	4.7		
				$V_{CCB} = 5 V \pm 0.5 V$	5.8		
			Open-drain driving	$V_{CCB} = 2.5 V \pm 0.2 V$	3.1	9.0	
				$V_{CCB} = 3.3 V \pm 0.3 V$	4.2	11.9	
				$V_{CCB} = 5 V \pm 0.5 V$	6.3	17.6	
t _{PLH}	Propagation delay time (low-to-high output)	A-to-B	Push-pull driving	$V_{CCB} = 2.5 V \pm 0.2 V$	6.8		ns
				$V_{CCB} = 3.3 V \pm 0.3 V$	6.8		
				$V_{CCB} = 5 V \pm 0.5 V$	7		
			Open-drain driving	$V_{CCB} = 2.5 V \pm 0.2 V$	45	260	
				$V_{CCB} = 3.3 V \pm 0.3 V$	36	208	
				$V_{CCB} = 5 V \pm 0.5 V$	27	198	
t _{PHL}	Propagation delay time (high-to-low output)	B-to-A	Push-pull driving	$V_{CCB} = 2.5 V \pm 0.2 V$	4.4		ns
				$V_{CCB} = 3.3 V \pm 0.3 V$	4.5		
				$V_{CCB} = 5 V \pm 0.5 V$	4.7		
			Open-drain driving	$V_{CCB} = 2.5 V \pm 0.2 V$	1.9	5.3	
				$V_{CCB} = 3.3 V \pm 0.3 V$	1.5	4.4	
				$V_{CCB} = 5 V \pm 0.5 V$	1.2	4.0	
t _{PLH}	Propagation delay time (low-to-high output)	B-to-A	Push-pull driving	$V_{CCB} = 2.5 V \pm 0.2 V$	5.3		ns
				$V_{CCB} = 3.3 V \pm 0.3 V$	4.5		
				$V_{CCB} = 5 V \pm 0.5 V$	1.8		
			Open-drain driving	$V_{CCB} = 2.5 V \pm 0.2 V$	45	175	
				$V_{CCB} = 3.3 V \pm 0.3 V$	36	140	
				$V_{CCB} = 5 V \pm 0.5 V$	27	102	
t _{en}	Enable time	OE-to-A or B	$V_{CCB} = 2.5 V \pm 0.2 V$	36		ns	
			$V_{CCB} = 3.3 V \pm 0.3 V$	41			
			$V_{CCB} = 5 V \pm 0.5 V$	43			
t _{dis}	Disable time	OE-to-A or B	$V_{CCB} = 2.5 V \pm 0.2 V$	77		ns	
			$V_{CCB} = 3.3 V \pm 0.3 V$	68			
			$V_{CCB} = 5 V \pm 0.5 V$	63			
t _{rA}	Input rise time	A-port rise time	Push-pull driving	$V_{CCB} = 2.5 V \pm 0.2 V$	3.4	9.5	ns
				$V_{CCB} = 3.3 V \pm 0.3 V$	2.7	9.3	
				$V_{CCB} = 5 V \pm 0.5 V$	2.2	8.0	
			Open-drain driving	$V_{CCB} = 2.5 V \pm 0.2 V$	38	165	
				$V_{CCB} = 3.3 V \pm 0.3 V$	30	132	
				$V_{CCB} = 5 V \pm 0.5 V$	22	95	
t _{rB}	Input rise time	B-port rise time	Push-pull driving	$V_{CCB} = 2.5 V \pm 0.2 V$	4	10.8	ns
				$V_{CCB} = 3.3 V \pm 0.3 V$	3.2	9.1	
				$V_{CCB} = 5 V \pm 0.5 V$	4.3	7.6	
			Open-drain driving	$V_{CCB} = 2.5 V \pm 0.2 V$	34	145	
				$V_{CCB} = 3.3 V \pm 0.3 V$	23	106	
				$V_{CCB} = 5 V \pm 0.5 V$	10	58	



over recommended operating free-air temperature range, $V_{CCA} = 1.8 \text{ V} \pm 0.15 \text{ V}$ (unless otherwise noted)

PARAMETER		TEST CONDITIONS		MIN	MAX	UNIT	
t_{fA}	Input fall time	A-port fall time	Push-pull driving	$V_{CCB} = 2.5 \text{ V} \pm 0.2 \text{ V}$	2	5.9	ns
				$V_{CCB} = 3.3 \text{ V} \pm 0.3 \text{ V}$	1.9	6.0	
				$V_{CCB} = 5 \text{ V} \pm 0.5 \text{ V}$	1.7	13.3	
		Open-drain driving	$V_{CCB} = 2.5 \text{ V} \pm 0.2 \text{ V}$	4.4	7.6		
			$V_{CCB} = 3.3 \text{ V} \pm 0.3 \text{ V}$	4.3	6.4		
			$V_{CCB} = 5 \text{ V} \pm 0.5 \text{ V}$	4.2	6.1		
t_{fB}	Input fall time	B-port fall time	Push-pull driving	$V_{CCB} = 2.5 \text{ V} \pm 0.2 \text{ V}$	2.9	7.6	ns
				$V_{CCB} = 3.3 \text{ V} \pm 0.3 \text{ V}$	2.8	7.5	
				$V_{CCB} = 5 \text{ V} \pm 0.5 \text{ V}$	2.8	8.8	
		Open-drain driving	$V_{CCB} = 2.5 \text{ V} \pm 0.2 \text{ V}$	6.9	13.8		
			$V_{CCB} = 3.3 \text{ V} \pm 0.3 \text{ V}$	7.5	20.0		
			$V_{CCB} = 5 \text{ V} \pm 0.5 \text{ V}$	10.2	32.3		
$t_{SK(O)}$	Skew (time), output	Channel-to-channel skew		$V_{CCB} = 2.5 \text{ V} \pm 0.2 \text{ V}$	1		ns
				$V_{CCB} = 3.3 \text{ V} \pm 0.3 \text{ V}$	1		
				$V_{CCB} = 5 \text{ V} \pm 0.5 \text{ V}$	1		
Maximum data rate		Push-pull driving	$V_{CCB} = 2.5 \text{ V} \pm 0.2 \text{ V}$	24		Mbps	
			$V_{CCB} = 3.3 \text{ V} \pm 0.3 \text{ V}$	24			
			$V_{CCB} = 5 \text{ V} \pm 0.5 \text{ V}$	24			
		Open-drain driving	$V_{CCB} = 2.5 \text{ V} \pm 0.2 \text{ V}$	2			
			$V_{CCB} = 3.3 \text{ V} \pm 0.3 \text{ V}$	2			
			$V_{CCB} = 5 \text{ V} \pm 0.5 \text{ V}$	2			

6.7 Switching Characteristics: $V_{CCA} = 2.5 \text{ V} \pm 0.2 \text{ V}$

over recommended operating free-air temperature range, $V_{CCA} = 2.5 \text{ V} \pm 0.2 \text{ V}$ (unless otherwise noted)

PARAMETER		TEST CONDITIONS		MIN	MAX	UNIT	
t_{PHL}	Propagation delay time (high-to-low output)	A-to-B	Push-pull driving	$V_{CCB} = 2.5 \text{ V} \pm 0.2 \text{ V}$	3.2		ns
				$V_{CCB} = 3.3 \text{ V} \pm 0.3 \text{ V}$	3.3		
				$V_{CCB} = 5 \text{ V} \pm 0.5 \text{ V}$	3.4		
		Open-drain driving	$V_{CCB} = 2.5 \text{ V} \pm 0.2 \text{ V}$	1.7	6.3		
			$V_{CCB} = 3.3 \text{ V} \pm 0.3 \text{ V}$	2	6		
			$V_{CCB} = 5 \text{ V} \pm 0.5 \text{ V}$	2.1	5.8		
t_{PLH}	Propagation delay time (low-to-high output)	A-to-B	Push-pull driving	$V_{CCB} = 2.5 \text{ V} \pm 0.2 \text{ V}$	3.5		ns
				$V_{CCB} = 3.3 \text{ V} \pm 0.3 \text{ V}$	4.1		
				$V_{CCB} = 5 \text{ V} \pm 0.5 \text{ V}$	4.4		
		Open-drain driving	$V_{CCB} = 2.5 \text{ V} \pm 0.2 \text{ V}$	43	250		
			$V_{CCB} = 3.3 \text{ V} \pm 0.3 \text{ V}$	36	206		
			$V_{CCB} = 5 \text{ V} \pm 0.5 \text{ V}$	27	190		
t_{PHL}	Propagation delay time (high-to-low output)	B-to-A	Push-pull driving	$V_{CCB} = 2.5 \text{ V} \pm 0.2 \text{ V}$	3		ns
				$V_{CCB} = 3.3 \text{ V} \pm 0.3 \text{ V}$	3.6		
				$V_{CCB} = 5 \text{ V} \pm 0.5 \text{ V}$	4.3		
		Open-drain driving	$V_{CCB} = 2.5 \text{ V} \pm 0.2 \text{ V}$	1.8	4.7		
			$V_{CCB} = 3.3 \text{ V} \pm 0.3 \text{ V}$	2.6	4.2		
			$V_{CCB} = 5 \text{ V} \pm 0.5 \text{ V}$	1.2	4.0		



over recommended operating free-air temperature range, $V_{CCA} = 2.5 \text{ V} \pm 0.2 \text{ V}$ (unless otherwise noted)

PARAMETER		TEST CONDITIONS		MIN	MAX	UNIT	
t_{PLH}	Propagation delay time (low-to-high output)	B-to-A	Push-pull driving	$V_{CCB} = 2.5 \text{ V} \pm 0.2 \text{ V}$	2.5		
				$V_{CCB} = 3.3 \text{ V} \pm 0.3 \text{ V}$	1.8		
				$V_{CCB} = 5 \text{ V} \pm 0.5 \text{ V}$	1.5		
		Open-drain driving	$V_{CCB} = 2.5 \text{ V} \pm 0.2 \text{ V}$	44	170		
			$V_{CCB} = 3.3 \text{ V} \pm 0.3 \text{ V}$	37	140		
			$V_{CCB} = 5 \text{ V} \pm 0.5 \text{ V}$	27	103		
t_{en}	Enable time	OE-to-A or B	$V_{CCB} = 2.5 \text{ V} \pm 0.2 \text{ V}$	36		ns	
			$V_{CCB} = 3.3 \text{ V} \pm 0.3 \text{ V}$	41			
			$V_{CCB} = 5 \text{ V} \pm 0.5 \text{ V}$	43			
t_{dis}	Disable time	OE-to-A or B	$V_{CCB} = 2.5 \text{ V} \pm 0.2 \text{ V}$	77		ns	
			$V_{CCB} = 3.3 \text{ V} \pm 0.3 \text{ V}$	68			
			$V_{CCB} = 5 \text{ V} \pm 0.5 \text{ V}$	63			
t_{rA}	Input rise time	A-port rise time	Push-pull driving	$V_{CCB} = 2.5 \text{ V} \pm 0.2 \text{ V}$	2.8	7.4	ns
				$V_{CCB} = 3.3 \text{ V} \pm 0.3 \text{ V}$	2.6	6.6	
				$V_{CCB} = 5 \text{ V} \pm 0.5 \text{ V}$	1.8	5.6	
		Open-drain driving	$V_{CCB} = 2.5 \text{ V} \pm 0.2 \text{ V}$	34	149		
			$V_{CCB} = 3.3 \text{ V} \pm 0.3 \text{ V}$	31	121		
			$V_{CCB} = 5 \text{ V} \pm 0.5 \text{ V}$	24	89		
t_{rB}	Input rise time	B-port rise time	Push-pull driving	$V_{CCB} = 2.5 \text{ V} \pm 0.2 \text{ V}$	3.2	8.3	ns
				$V_{CCB} = 3.3 \text{ V} \pm 0.3 \text{ V}$	2.9	7.2	
				$V_{CCB} = 5 \text{ V} \pm 0.5 \text{ V}$	2.6	6.2	
		Open-drain driving	$V_{CCB} = 2.5 \text{ V} \pm 0.2 \text{ V}$	35	151		
			$V_{CCB} = 3.3 \text{ V} \pm 0.3 \text{ V}$	31	112		
			$V_{CCB} = 5 \text{ V} \pm 0.5 \text{ V}$	16.5	64		
t_{fA}	Input fall time	A-port fall time	Push-pull driving	$V_{CCB} = 2.5 \text{ V} \pm 0.2 \text{ V}$	1.9	5.7	ns
				$V_{CCB} = 3.3 \text{ V} \pm 0.3 \text{ V}$	1.9	5.5	
				$V_{CCB} = 5 \text{ V} \pm 0.5 \text{ V}$	1.8	5.3	
		Open-drain driving	$V_{CCB} = 2.5 \text{ V} \pm 0.2 \text{ V}$	4.4	6.9		
			$V_{CCB} = 3.3 \text{ V} \pm 0.3 \text{ V}$	4.3	6.2		
			$V_{CCB} = 5 \text{ V} \pm 0.5 \text{ V}$	4.2	5.8		
t_{fB}	Input fall time	B-port fall time	Push-pull driving	$V_{CCB} = 2.5 \text{ V} \pm 0.2 \text{ V}$	2.2	7.8	ns
				$V_{CCB} = 3.3 \text{ V} \pm 0.3 \text{ V}$	2.4	6.7	
				$V_{CCB} = 5 \text{ V} \pm 0.5 \text{ V}$	2.6	6.6	
		Open-drain driving	$V_{CCB} = 2.5 \text{ V} \pm 0.2 \text{ V}$	5.1	8.8		
			$V_{CCB} = 3.3 \text{ V} \pm 0.3 \text{ V}$	5.4	9.4		
			$V_{CCB} = 5 \text{ V} \pm 0.5 \text{ V}$	5.4	11.2		
$t_{SK(O)}$	Skew (time), output	Channel-to-channel skew	$V_{CCB} = 2.5 \text{ V} \pm 0.2 \text{ V}$	1		ns	
			$V_{CCB} = 3.3 \text{ V} \pm 0.3 \text{ V}$	1			
			$V_{CCB} = 5 \text{ V} \pm 0.5 \text{ V}$	1			



over recommended operating free-air temperature range, $V_{CCA} = 2.5 \text{ V} \pm 0.2 \text{ V}$ (unless otherwise noted)

PARAMETER		TEST CONDITIONS		MIN	MAX	UNIT
Maximum data rate		Push-pull driving	$V_{CCB} = 2.5 \text{ V} \pm 0.2 \text{ V}$	24		Mbps
			$V_{CCB} = 3.3 \text{ V} \pm 0.3 \text{ V}$	24		
			$V_{CCB} = 5 \text{ V} \pm 0.5 \text{ V}$	24		
		Open-drain driving	$V_{CCB} = 2.5 \text{ V} \pm 0.2 \text{ V}$	2		
			$V_{CCB} = 3.3 \text{ V} \pm 0.3 \text{ V}$	2		
			$V_{CCB} = 5 \text{ V} \pm 0.5 \text{ V}$	2		

6.8 Switching Characteristics: $V_{CCA}=3.3\text{V}\pm 0.3\text{V}$

over recommended operating free-air temperature range, $V_{CCA} = 3.3 \text{ V} \pm 0.3 \text{ V}$ (unless otherwise noted)

PARAMETER		TEST CONDITIONS		MIN	MAX	UNIT	
t_{PHL}	Propagation delay time (high-to-low output)	A-to-B	Push-pull driving	$V_{CCB} = 3.3 \text{ V} \pm 0.3 \text{ V}$	2.4		ns
				$V_{CCB} = 5 \text{ V} \pm 0.5 \text{ V}$	3.1		
			Open-drain driving	$V_{CCB} = 3.3 \text{ V} \pm 0.3 \text{ V}$	1.3	4.2	
				$V_{CCB} = 5 \text{ V} \pm 0.5 \text{ V}$	1.7	4.6	
t_{PLH}	Propagation delay time (low-to-high output)	A-to-B	Push-pull driving	$V_{CCB} = 3.3 \text{ V} \pm 0.3 \text{ V}$	4.2		
				$V_{CCB} = 5 \text{ V} \pm 0.5 \text{ V}$	4.4		
			Open-drain driving	$V_{CCB} = 3.3 \text{ V} \pm 0.3 \text{ V}$	40	204	
				$V_{CCB} = 5 \text{ V} \pm 0.5 \text{ V}$	34	165	
t_{PHL}	Propagation delay time (high-to-low output)	B-to-A	Push-pull driving	$V_{CCB} = 3.3 \text{ V} \pm 0.3 \text{ V}$	2.5		ns
				$V_{CCB} = 5 \text{ V} \pm 0.5 \text{ V}$	3.3		
			Open-drain driving	$V_{CCB} = 3.3 \text{ V} \pm 0.3 \text{ V}$	1	124	
				$V_{CCB} = 5 \text{ V} \pm 0.5 \text{ V}$	1	97	
t_{PLH}	Propagation delay time (low-to-high output)	B-to-A	Push-pull driving	$V_{CCB} = 3.3 \text{ V} \pm 0.3 \text{ V}$	2.5		
				$V_{CCB} = 5 \text{ V} \pm 0.5 \text{ V}$	2.6		
			Open-drain driving	$V_{CCB} = 3.3 \text{ V} \pm 0.3 \text{ V}$	3	139	
				$V_{CCB} = 5 \text{ V} \pm 0.5 \text{ V}$	3	105	
t_{en}	Enable time	OE-to-A or B	$V_{CCB} = 3.3 \text{ V} \pm 0.3 \text{ V}$	41		ns	
			$V_{CCB} = 5 \text{ V} \pm 0.5 \text{ V}$	43			
t_{dis}	Disable time	OE-to-A or B	$V_{CCB} = 3.3 \text{ V} \pm 0.3 \text{ V}$	68		ns	
			$V_{CCB} = 5 \text{ V} \pm 0.5 \text{ V}$	63			
t_{rA}	Input rise time	A-port rise time	Push-pull driving	$V_{CCB} = 3.3 \text{ V} \pm 0.3 \text{ V}$	2.3	5.6	ns
				$V_{CCB} = 5 \text{ V} \pm 0.5 \text{ V}$	1.9	4.8	
			Open-drain driving	$V_{CCB} = 3.3 \text{ V} \pm 0.3 \text{ V}$	25	116	
				$V_{CCB} = 5 \text{ V} \pm 0.5 \text{ V}$	19	85	
t_{rB}	Input rise time	B-port rise time	Push-pull driving	$V_{CCB} = 3.3 \text{ V} \pm 0.3 \text{ V}$	2.5	6.4	ns
				$V_{CCB} = 5 \text{ V} \pm 0.5 \text{ V}$	2.1	7.4	
			Open-drain driving	$V_{CCB} = 3.3 \text{ V} \pm 0.3 \text{ V}$	25	116	
				$V_{CCB} = 5 \text{ V} \pm 0.5 \text{ V}$	26	116	
t_{fA}	Input fall time	A-port fall time	Push-pull driving	$V_{CCB} = 3.3 \text{ V} \pm 0.3 \text{ V}$	2	5.4	ns
				$V_{CCB} = 5 \text{ V} \pm 0.5 \text{ V}$	1.9	5.0	
			Open-drain driving	$V_{CCB} = 3.3 \text{ V} \pm 0.3 \text{ V}$	4.3	6.1	
				$V_{CCB} = 5 \text{ V} \pm 0.5 \text{ V}$	4.2	5.7	



over recommended operating free-air temperature range, $V_{CCA} = 3.3\text{ V} \pm 0.3\text{ V}$ (unless otherwise noted)

PARAMETER		TEST CONDITIONS		MIN	MAX	UNIT	
t_{FB}	Input fall time	B-port fall time	Push-pull driving	$V_{CCB} = 3.3\text{ V} \pm 0.3\text{ V}$	2.3	7.4	ns
				$V_{CCB} = 5\text{ V} \pm 0.5\text{ V}$	2.4	7.6	
			Open-drain driving	$V_{CCB} = 3.3\text{ V} \pm 0.3\text{ V}$	5	7.6	
				$V_{CCB} = 5\text{ V} \pm 0.5\text{ V}$	4.8	8.3	
$t_{SK(O)}$ Skew (time), output	Channel-to-channel skew		$V_{CCB} = 3.3\text{ V} \pm 0.3\text{ V}$	1		ns	
			$V_{CCB} = 5\text{ V} \pm 0.5\text{ V}$	1			
Maximum data rate			Push-pull driving	$V_{CCB} = 3.3\text{ V} \pm 0.3\text{ V}$	24		Mbps
				$V_{CCB} = 5\text{ V} \pm 0.5\text{ V}$	24		
			Open-drain driving	$V_{CCB} = 3.3\text{ V} \pm 0.3\text{ V}$	2		
				$V_{CCB} = 5\text{ V} \pm 0.5\text{ V}$	2		

6.9 Switching Characteristics: $V_{CCA} = 5\text{ V} \pm 0.5\text{ V}$

over recommended operating free-air temperature range, $V_{CCA} = 5\text{ V} \pm 0.5\text{ V}$ (unless otherwise noted)

PARAMETER		TEST CONDITIONS		MIN	MAX	UNIT	
t_{PHL}	Propagation delay time (high-to-low output)		Push-pull driving	$V_{CCB} = 5\text{ V} \pm 0.5\text{ V}$	5.6		ns
			Open-drain driving	$V_{CCB} = 5\text{ V} \pm 0.5\text{ V}$	1.6	4.6	
t_{PLH}	Propagation delay time (low-to-high output)		Push-pull driving	$V_{CCB} = 5\text{ V} \pm 0.5\text{ V}$	2.0		
			Open-drain driving	$V_{CCB} = 5\text{ V} \pm 0.5\text{ V}$	24	155	
t_{en}	Enable time	OE-to-A or B		$V_{CCB} = 5\text{ V} \pm 0.5\text{ V}$	43		ns
t_{dis}	Disable time	OE-to-A or B		$V_{CCB} = 5\text{ V} \pm 0.5\text{ V}$	63		ns
t_r	Input rise time		Push-pull driving	$V_{CCB} = 5\text{ V} \pm 0.5\text{ V}$	2.7	5.0	ns
			Open-drain driving	$V_{CCB} = 5\text{ V} \pm 0.5\text{ V}$	19	50	
t_f	Input fall time		Push-pull driving	$V_{CCB} = 5\text{ V} \pm 0.5\text{ V}$	1.2	3.0	ns
			Open-drain driving	$V_{CCB} = 5\text{ V} \pm 0.5\text{ V}$	1.8	3.0	
$t_{SK(O)}$ Skew (time), output	Channel-to-channel skew		$V_{CCB} = 5\text{ V} \pm 0.5\text{ V}$	1		ns	
Maximum data rate			Push-pull driving	$V_{CCB} = 5\text{ V} \pm 0.5\text{ V}$	24		Mbps
			Open-drain driving	$V_{CCB} = 5\text{ V} \pm 0.5\text{ V}$	2		

7. Parameter Measurement Information

7.1 Load Circuits

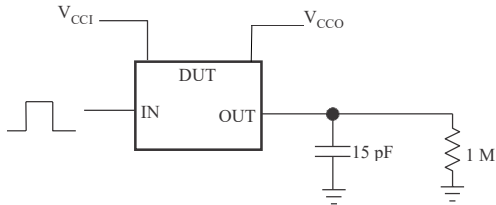

Figure 7-1. Data Rate, Pulse Duration, Propagation Delay, Output Rise-Time and Fall-Time Measurement Using a Push-Pull Driver

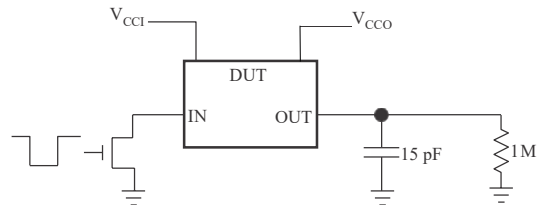
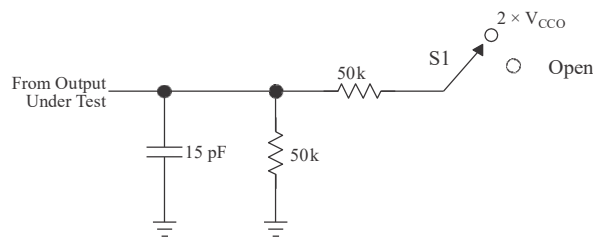

Figure 7-2. Data Rate, Pulse Duration, Propagation Delay, Output Rise-Time and Fall-Time Measurement Using an Open-Drain Driver



TEST	S1
t_{PZL} / t_{PLZ} (t_{dis})	$2 \times V_{CCO}$
t_{PHZ} / t_{PZH} (t_{en})	Open

Figure 7-3. Load Circuit for Enable-Time and Disable-Time Measurement

1. t_{PZL} and t_{PHZ} are the same as t_{dis} .
2. t_{PZL} and t_{PZH} are the same as t_{en} .
3. V_{CCI} is the V_{CC} associated with the input port.
4. V_{CCO} is the V_{CC} associated with the output port.

7.2 Voltage Waveforms

The outputs are measured one at a time, with one transition per measurement. All input pulses are supplied by generators that have the following characteristics:

- $PRR \leq 10 \text{ MHz}$
- $Z_o = 50 \Omega$
- $dv/dt \geq 1 \text{ V/ns}$

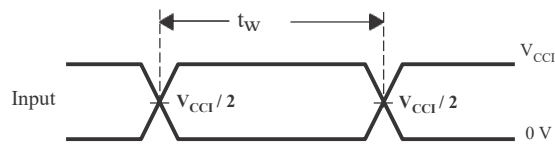

Figure 7-4. Pulse Duration

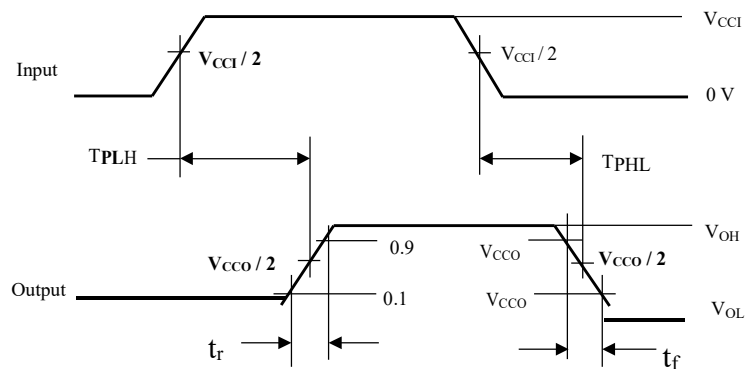
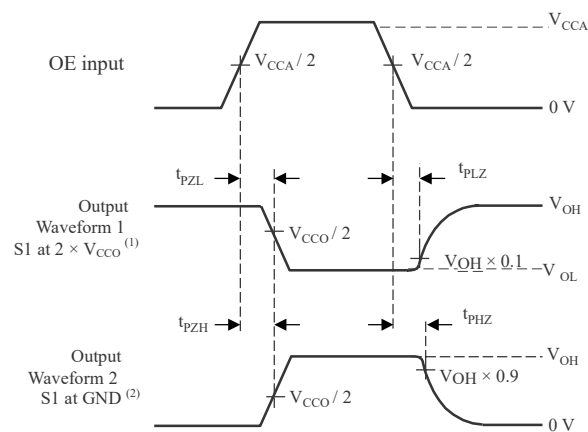

Figure 7-5. Voltage Waveforms Propagation Delay Times



- A. Waveform 1 is for an output with internal such that the output is high, except when OE is high (see Figure 7-3).
 B. Waveform 2 is for an output with conditions such that the output is low, except when OE is high.

Figure 7-6. Enable and Disable Times



8. Application Information

The SC0102 device can be used to bridge the digital-switching compatibility gap between two voltage nodes to successfully interface logic threshold levels found in electronic systems. It should be used in a point-to-point topology for interfacing devices or systems operating at different interface voltages with one another. Its primary target application use is for interfacing with open-drain drivers on the data I/Os such as I2C , where the data is bidirectional and no control signal is available. The device can also be used in applications where a push-pull driver is connected to the data I/Os.

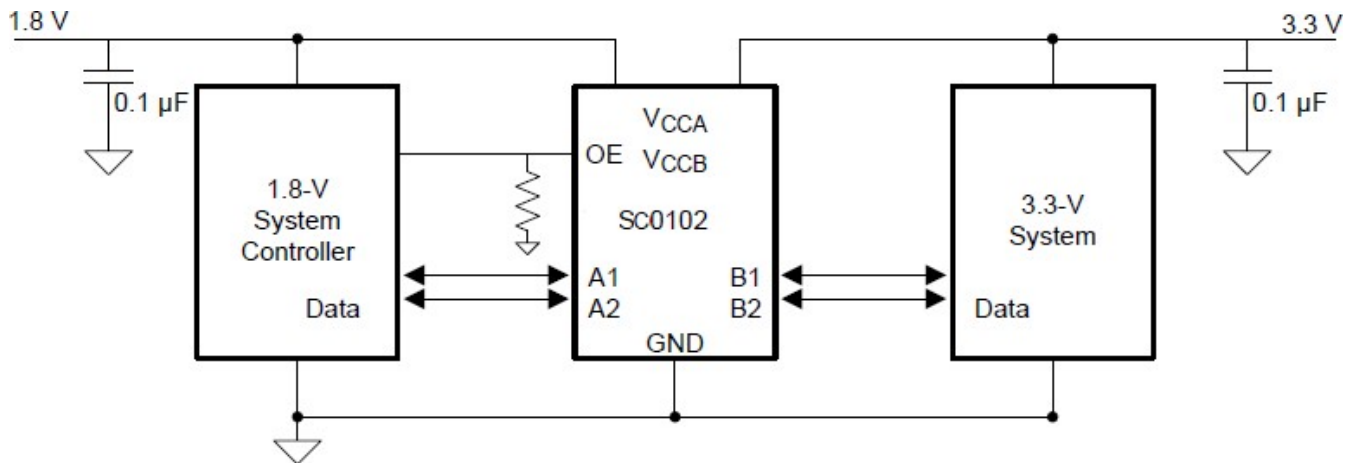

9. Feature Description

9.1 Architecture

The SC0102 architecture (see Figure 8) is an auto-direction-sensing based translator that does not require a direction-control signal to control the direction of data flow from A to B or from B to A. These two bidirectional channels independently determine the direction of data flow without a direction-control signal. Each I/O pin can be automatically reconfigured as either an input or an output, which is how this auto-direction feature is realized.

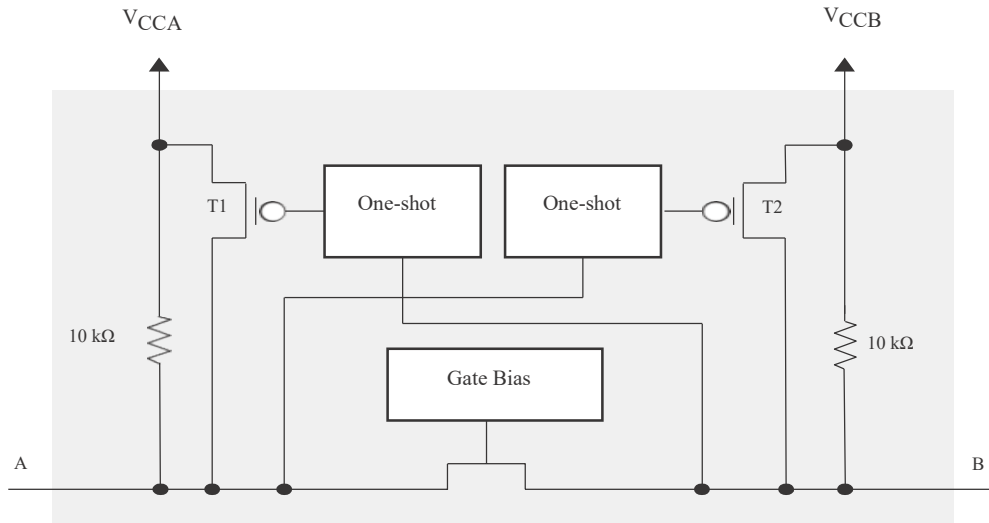

Figure 8-1. Architecture of a SC0104 Cell

9.2 Power Up

During operation, ensure that $V_{CCA} \leq V_{CCB}$ at all times. During power-up sequencing, $V_{CCA} \geq V_{CCB}$ does not damage the device, so any power supply can be ramped up first.

9.3 Enable and Disable

The SC0102 device has an OE input that disables the device by setting OE low, which places all I/Os in the high-impedance state. The disable time (t_{dis}) indicates the delay between the time when the OE pin goes low and when the outputs actually enter the high-impedance state. The enable time (t_{en}) indicates the amount of time the user must allow for the one-shot circuitry to become operational after the OE pin is taken high.

9.4 Pullup and Pulldown Resistors on I/O Lines

Each A-port I/O has an internal 10-kΩ pullup resistor to V_{CCA} , and each B-port I/O has an internal 10-kΩ pullup resistor to V_{CCB} . If a smaller value of pullup resistor is required, an external resistor must be added from the I/O to V_{CCA} or V_{CCB} (in parallel with the internal 10-kΩ resistors).



9.5 Output Load Considerations

We recommend careful PCB layout practices with short PCB trace lengths to avoid excessive capacitive loading and to ensure that proper O.S. triggering takes place. PCB signal trace-lengths should be kept short enough such that the round-trip delay of any reflection is less than the one-shot duration. This improves signal integrity by ensuring that any reflection sees a low impedance at the driver. The O.S. circuits have been designed to stay on for approximately 30 ns. The maximum capacitance of the lumped load that can be driven also depends directly on the one-shot duration. With very heavy capacitive loads, the one-shot can time-out before the signal is driven fully to the positive rail. The O.S. duration has been set to best optimize trade-offs between dynamic ICC, load driving capability, and maximum bit-rate considerations. Both PCB trace length and connectors add to the capacitance that the RS0104 device output sees, so it is recommended that this lumped-load capacitance be considered to avoid O.S. retriggering, bus contention, output signal oscillations, or other adverse system level affects.

9.6 Input Driver Requirements

The fall time (t_{fA} , t_{fB}) of a signal depends on the output impedance of the external device driving the data I/Os of the SC0102 device. Similarly, the t_{PHL} and maximum data rates also depend on the output impedance of the external driver. The values for t_{fA} , t_{fB} , t_{PHL} , and maximum data rates in the data sheet assume that the output impedance of the external driver is less than 50 Ω .



PACKAGE OUTLINE DIMENSIONS

SOT-23-8

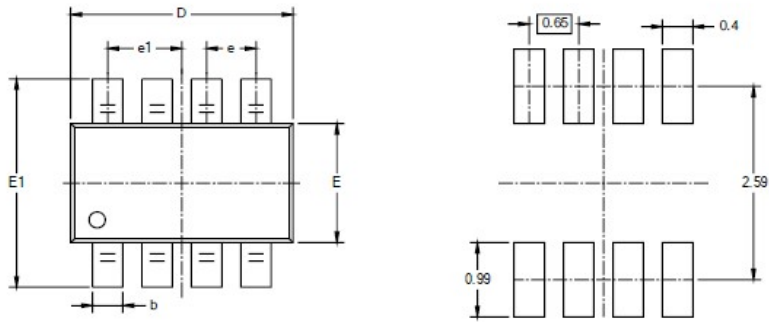

RECOMMENDED LAND PATTERN (Unit: mm)

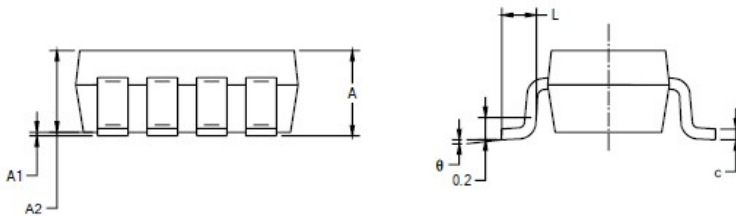

Symbol	Dimensions In Millimeters		Dimensions In Inches	
	Min	Max	Min	Max
A	1.050	1.250	0.041	0.049
A1	0.000	0.100	0.000	0.004
A2	1.050	1.150	0.041	0.045
b	0.300	0.500	0.012	0.020
c	0.100	0.200	0.004	0.008
D	2.820	3.020	0.111	0.119
E	1.500	1.700	0.059	0.067
E1	2.650	2.950	0.104	0.116
e	0.650(BSC)		0.026(BSC)	
e1	0.975(BSC)		0.038(BSC)	
L	0.300	0.600	0.012	0.024
θ	0°	8°	0°	8°



MSOP-8

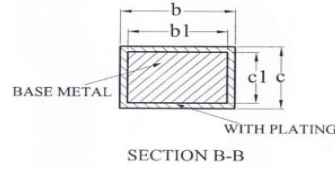
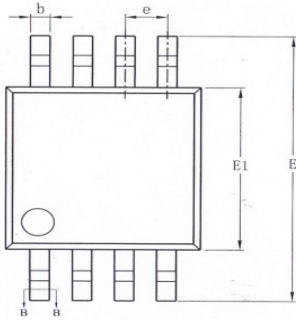
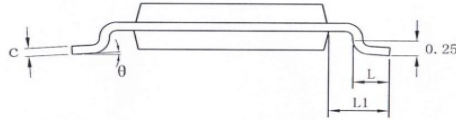
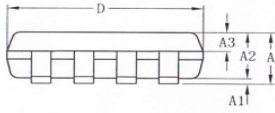

SYMBOL	MILLIMETER		
	MIN	NOM	MAX
A	—	—	1.10
A1	0.05	—	0.15
A2	0.75	0.85	0.95
A3	0.30	0.35	0.40
b	0.28	—	0.36
b1	0.27	0.30	0.33
c	0.15	—	0.19
c1	0.14	0.15	0.16
D	2.90	3.00	3.10
E	4.70	4.90	5.10
E1	2.90	3.00	3.10
e	0.65BSC		
L	0.40	—	0.70
L1	0.95REF		
theta	0	—	8°



Version History:

Ver.	Date	Changes	Author	Notes
Initial(V0.1)	2023-11-12		Yahui.He	