

Dual Low-Voltage H-bridge Motor Driver

1. Feature

- Dual H-Bridge Motor Driver
- Capable of Driving Two DC Motors or One Stepper Motor
- Low-MOSFET ON-Resistance
 - HS + LS 305 mΩ
- 1.5 A Maximum Drive Current Per H-Bridge
- Configure Bridges Parallel for 3 A Drive Current
- Separate Motor and Logic-Supply Pins
- 0V to 11V Motor-Operating Supply-Voltage
- 2V to 7V Logic Supply-Voltage
- Flexible PWM or PHASE/ENABLE Interface
- Low-Power Sleep Mode With 95nA Maximum Supply Current
- DFN12L - 2mm x 3mm Package

2. Applications

- Battery-Powered:
 - Cameras
 - DSLR Lenses
 - Consumer Products
 - Toys
 - Robotics
 - Medical Devices

3. General Description

The SC8835 provides an integrated motor driver solution for cameras, consumer products, toys, and other low-voltage or battery-powered motion control applications. The device has two H-bridge drivers, and drives two DC motors or one stepper motor, as well as other devices like solenoids. The output driver block for each consists of N-channel power MOSFETs configured as an H-bridge to drive the motor winding. An internal charge pump generates gate drive voltages.

The SC8835 supplies up to 1.5A of output current per H-bridge and operates on a motor power supply voltage from 0V to 11V, and a device power supply voltage of 2V to 7V.

PHASE/ENABLE and IN/IN interfaces are compatible with industry-standard devices.

Internal shutdown functions are provided for overcurrent protection, short circuit protection, under voltage lockout, and over temperature.

The SC8835 is packaged in a 12-pin DFN package.

4. Device Information

Part Number	Package	Body Size
SC8835	DFN12L	2mm x 3mm

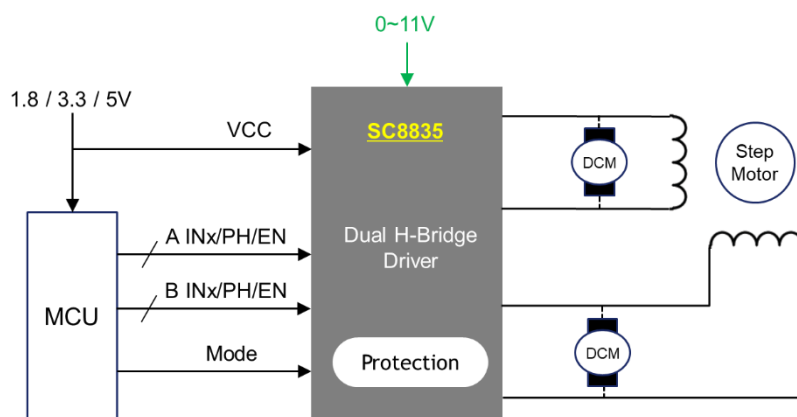

Information furnished by SteadiChips is believed to be accurate and reliable. However, no responsibility is assumed by SteadiChips for its use, or for any infringements of patents or other rights of third parties which may result from its use. No license is granted by implication or otherwise under any patent or patent rights of SteadiChips.

5. Pin Configuration

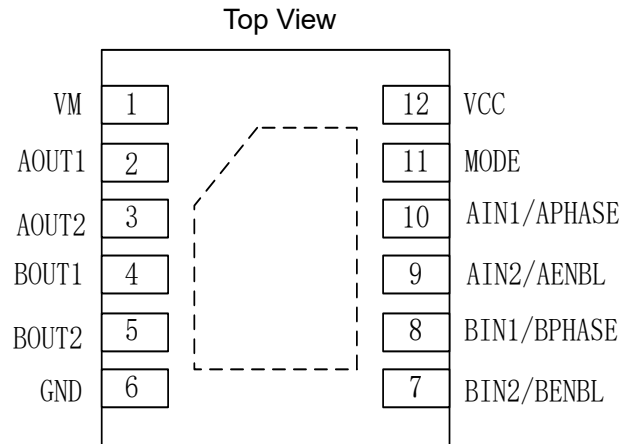

Fig. 1 Pin Definition

Table. 1 Pin Function Description

NO.	NAME	TYPE	DESCRIPTION	EXTERNAL COMPONENTS OR CONNECTIONS
1	VM	POWER	Motor supply	Bypass to GND with 0.1 μ F (minimum) ceramic capacitor
2	AOUT1	O	Bridge A output 1	Connect to motor winding A
3	AOUT2	O	Bridge A output 2	
4	BOUT1	O	Bridge B output 1	Connect to motor winding B
5	BOUT2	O	Bridge B output 2	
6	GND	GROUND	Device ground	
7	BIN2/BENBL	I	Bridge B input 2 / ENABLE input	IN/IN mode: Logic high sets BOUT2 high PH/EN mode: Logic high enables H-bridge B Internal pulldown resistor
8	BIN1/BPHASE	I	Bridge B input 1 / PHASE input	IN/IN mode: Logic high sets BOUT1 high PH/EN mode: Sets direction of H-bridge B Internal pulldown resistor
9	AIN2/AENBL	I	Bridge A input 2 / ENABLE input	IN/IN mode: Logic high sets AOUT2 high PH/EN mode: Logic high enables H-bridge A Internal pulldown resistor
10	AIN1/APHASE	I	Bridge A input 1 / PHASE input	IN/IN mode: Logic high sets AOUT1 high PH/EN mode: Sets direction of H-bridge A Internal pulldown resistor
11	MODE	I	Input mode select	Logic low selects IN/IN mode Logic high selects PH/EN mode Internal pulldown resistor
12	VCC	POWER	Device supply	Bypass to GND with 0.1 μ F(minimum) ceramic capacitor

6. Specifications

6.1. Absolute Maximum Ratings

(Stresses beyond those listed under Absolute Maximum Ratings may cause permanent damage to the device.)

SYMBOL	PARAMETER	MIN	MAX	UNITS
V _M	Motor power supply voltage	-0.3	12	V
V _{CC}	Power supply voltage	-0.3	7	V
T _A	Operating ambient Temperature Range	-40	125	°C
T _{STG}	Storage Temperature	-65	150	°C

6.2. Recommended Operating Conditions

SYMBOL	PARAMETER	MIN	MAX	UNITS
V _{CC}	Device power supply voltage	2	7	V
V _M	Motor power supply voltage	0	11	V
V _{IN}	Logic level input voltage	0	V _{CC}	V
I _{OUT}	H-bridge output current	0	1.5	A
f _{PWM}	Externally applied PWM frequency	0	250	kHz
T _A	Operating ambient Temperature Range	-40	85	°C

6.3. Thermal Information

SYMBOL	PARAMETER	VALUE	UNITS
R _{JA}	Junction-to-ambient thermal resistance	65.3	°C/W
R _{JC}	Junction-to-thermal resistance	45.8	°C/W

6.4. Electrical Characteristics

Specifications are at TA=+25°C, VM=5V, VCC=3V (unless otherwise noted)

SYMBOL	PARAMETER	TEST CONDITIONS	SPEC			UNITS
			MIN	TYP	MAX	
I _{VM}	VM operating supply current	No PWM, no load		194		μA
		50 kHz PWM, no load		350		
I _{VMQ}	VM sleep mode supply current	V _M =2V, V _{CC} =0V, all inputs 0V		5		nA
		V _M =5V, V _{CC} =0V, all inputs 0V		10	95	
I _{VCC}	VCC operating supply current			372		μA
V _{UVLO}	VCC undervoltage lockout voltage	VCC rising		1.5		V
		VCC falling		1.7		
V _{IL}	Input low voltage				0.3 x V _{CC}	V
V _{IH}	Input high voltage		0.5 x V _{CC}			V
I _{IL}	Input low current	V _{IN} =0			5	μA
I _{IH}	Input high current	V _{IN} =3.3V			50	μA
R _{PD}	Pulldown resistance			100		KΩ
R _{DS(ON)}	HS+LS FET on resistance	V _{CC} =3V, V _M =3V, I _o =800mA, T _J =25°C		337	400	mΩ
		V _{CC} =5V, V _M =5V, I _o =800mA, T _J =25°C		300	360	
I _{OFF}	OFF-state leakage current				200	nA
I _{OC}	Overcurrent protection trip level		1.6		3.5	A
t _{DEG}	Overcurrent de-glitch time			1		μs
t _{OCR}	Overcurrent protection retry time			1		ms
t _{DEAD}	Output dead time			100		ns
t _{TSD}	Thermal shutdown temperature		150	160	180	°C

6.5. Timing Requirements

TA=+25°C, VM=5V, VCC=3V, RL=20Ω

NO.	DESCRIPTION	MIN	MAX	UNIT
1	t ₁ Delay time, xPHASE high to xOUT1 low		300	ns
2	t ₂ Delay time, xPHASE high to xOUT2 high		200	ns
3	t ₃ Delay time, xPHASE low to xOUT1 high		200	ns
4	t ₄ Delay time, xPHASE low to xOUT2 low		300	ns
5	t ₅ Delay time, xENBL low to xOUTx high		200	ns
6	t ₆ Delay time, xENBL low to xOUTx low		300	ns
7	t ₇ Output enable time		300	ns
8	t ₈ Output disable time		300	ns
9	t ₉ Delay time, xINx high to xOUTx high		160	ns
10	t ₁₀ Delay time, xINx low to xOUTx low		160	ns
11	t _R Output rise time	30	188	ns
12	t _F Output fall time	30	188	ns

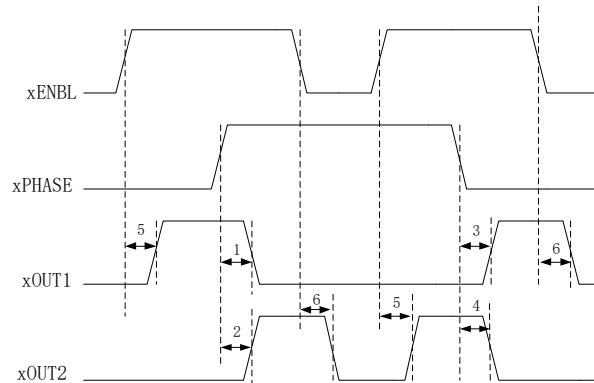

PHASE/ENBL mode

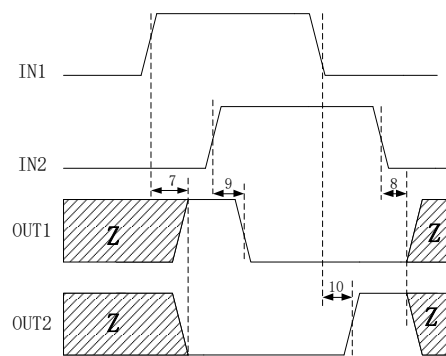

IN/IN mode

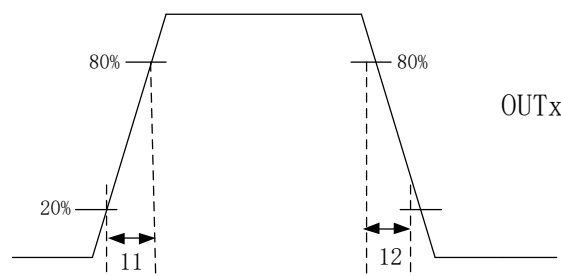

Fig. 2 Timing Requirements

7. Features Detailed Description

The SC8835 is an integrated motor-driver solution used for brushed motor control. The device integrates two H-bridges, and drives two DC motor or one stepper motor. The output driver block for each H-bridge consists of N-channel power MOSFETs. An internal charge pump generates the gate drive voltages. Protection features include overcurrent protection, short circuit protection, undervoltage lockout, and overtemperature protection.

The bridges connect in parallel for additional current capability.

The SC8835 allows separation of the motor voltage and logic voltage if desired. If VM and VCC are less than 7 V, the two voltages can be connected.

The mode pin allow selection of either a PHASE/ENABLE or IN/IN interface.

7.1. Protection Circuits

The SC8835 is fully protected against undervoltage, overcurrent, and overtemperature events.

1) Overcurrent Protection (OCP)

An analog current limit circuit on each FET limits the current through the FET by removing the gate drive. If this analog current limit persists for longer than the OCP time, all FETs in the H-bridge disable. After approximately 1ms, the bridge re-enable automatically.

Overcurrent conditions on both high-side and low-side devices; a short to ground, supply, or across the motor winding result in an overcurrent shutdown.

2) Thermal Shutdown (TSD)

If the die temperature exceeds safe limits, all FETs in the H-bridge disable. Operation automatically resumes once the die temperature falls to a safe level.

3) Undervoltage Lockout (UVLO)

If at any time the voltage on the VCC pins falls below the undervoltage lockout threshold voltage, all circuitry in the device disable, and internal logic resets. Operation resumes when VCC rises above the UVLO threshold.

Table. 2 Device Protection

FAULT	CONDITION	ERROR REPORT	H-BRIDGE	INTERNAL CIRCUITS	RECOVERY
VCC undervoltage (UVLO)	$VCC < VUVLO$	None	Disabled	Disabled	$VCC > VUVLO$
Overcurrent (OCP)	$I_{OUT} > I_{OCP}$	None	Disabled	Operating	tOCR
Thermal Shutdown (TSD)	$T_J > TTSD$	None	Disabled	Operating	$T_J < TTSD - THYS$

7.2. Bridge Control

Two control modes are available in the SC8835: IN/IN mode, and PHASE/ENABLE mode. IN/IN mode is selected if the MODE pin is driven low or left unconnected; PHASE/ENABLE mode is selected if the MODE pin is driven to logic high. **Table. 3** and **Table. 4** show the logic for these modes.

Table. 3 IN/IN Mode

MODE	xIN1	xIN2	xOUT1	xOUT2	FUNCTION (DC MOTOR)
0	0	0	Z	Z	Coast
0	0	1	L	H	Reverse
0	1	0	H	L	Forward
0	1	1	L	L	Brake

Table. 4 Phase/Enable Mode

MODE	xENABLE	xPHASE	xOUT1	xOUT2	FUNCTION (DC MOTOR)
1	0	X	L	L	Brake
1	1	1	L	H	Reverse
1	1	0	H	L	Forward

7.3. Sleep Mode

If the VCC pin reaches 0 V, the SC8835 enters a low-power sleep mode. In this state all unnecessary internal circuitry powers down. For minimum supply current, all inputs should be low (0 V) during sleep mode.

8. Application and Implementation

8.1. Application Information

The SC8835 is used in one or two motor control applications. Configure the SC8835 in parallel to provide double the current to one motor. The following design procedure can be used to configure the SC8835 in a brushed motor application.

8.2. Typical Application

The two H-bridges in the SC8835 drivers 1x Stepper motor or 2x DC motor. **Fig. 3** shows the connections.

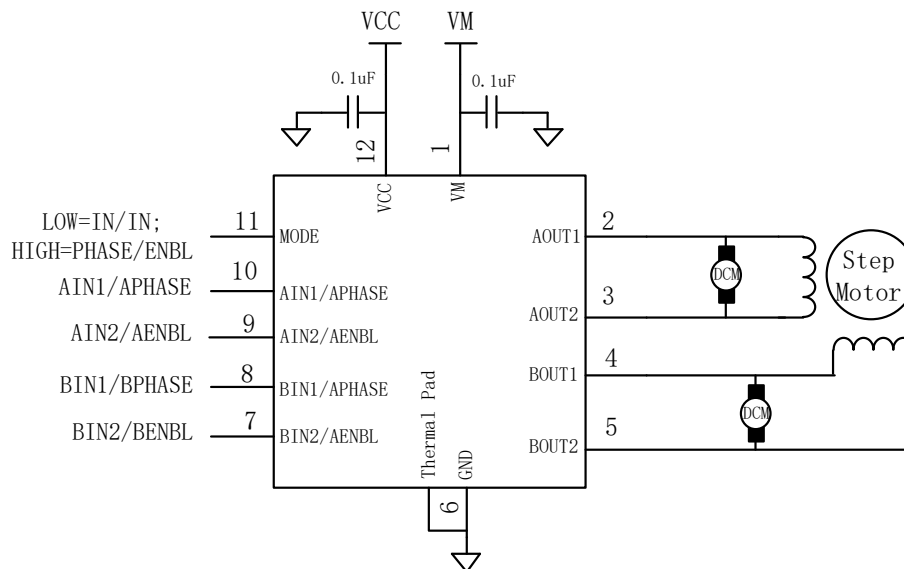

Fig. 3 Drivers 1x Stepper motor or 2x DC motor

The two H-bridges in the SC8835 connect in parallel for double the current of a single H-bridge. **Fig. 4** shows the connections.

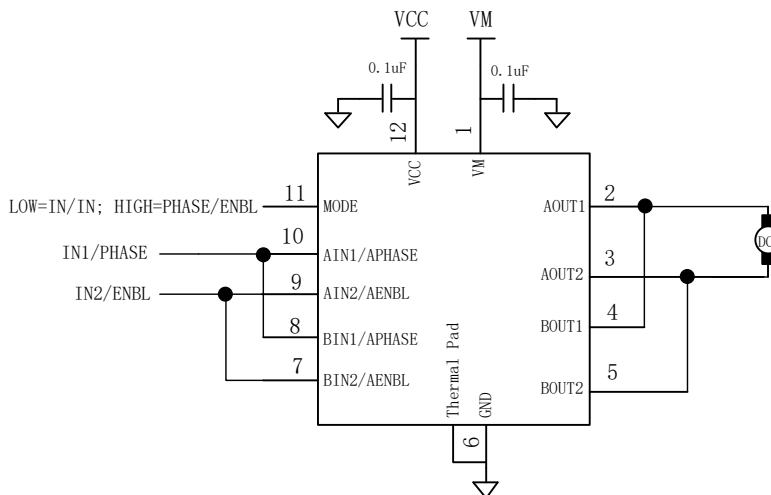
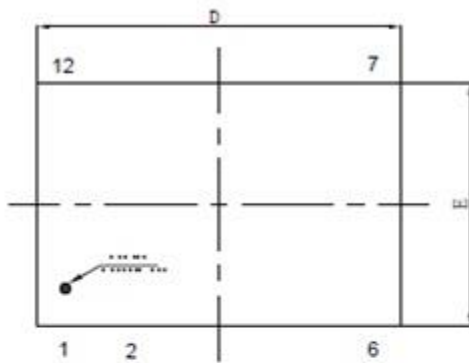

Fig. 4 Parallel Mode Connections

9. Package Outline Dimensions

DFN12L- 2mmx3mm

Symbol	Millimeters		
	MIN	NOM	MAX
A	0.70	0.75	0.80
A1	0	0.02	0.05
b	0.20	0.25	0.30
b1	0.18REF		
c	0.203REF		
D	2.90	3.00	3.10
D2	1.90	2.00	2.10
E	1.90	2.00	2.10
E2	0.80	0.90	1.00
E3	0.60	0.70	0.80
E4	0.10	0.20	0.30
e	0.50BSC		
Nd	2.50BSC		
L	0.25	0.30	0.35
R	0.05	0.10	0.15
K	0.25REF		



TOP VIEW

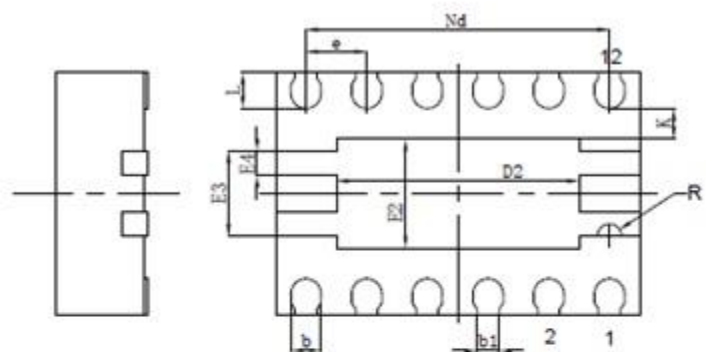

BOTTOM VIEW

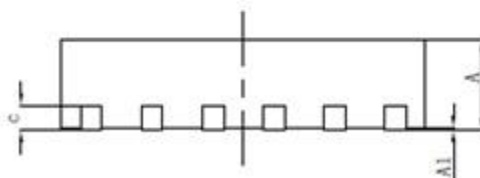

SIDE VIEW

REVISION HISTORY

DATE	REVISION	CHANGES
	1.0	Initial Release.
2020-8-12	1.1	Update some English words, sentences, descriptions, grammar and format.
2021-7-14	1.2	
2022-4-16	1.3	Update the document template.

DISCLAIMER

StediChips reserves the right to make changes to its products and to discontinue products without notice. The applications information, schematic diagrams, and other reference information included herein is provided as a design aid only and are therefore provided as-is. StediChips makes no warranties with respect to this information and disclaims any implied warranties of merchantability or non-infringement of third-party intellectual property rights.

StediChips cannot assume responsibility for use of any circuitry other than circuitry entirely embodied in an StediChips product. No circuit patent licenses are implied.

Certain applications using semiconductor products may involve potential risks of death, personal injury, or severe property or environmental damage (“Critical Applications”).

STEADICHIPS SEMICONDUCTOR PRODUCTS ARE NOT DESIGNED, INTENDED, AUTHORIZED, OR WARRANTED TO BE SUITABLE FOR USE IN LIFE-SUPPORT APPLICATIONS, DEVICES OR SYSTEMS, OR OTHER CRITICAL APPLICATIONS.

Inclusion of StediChips products in critical applications is understood to be fully at the risk of the customer. Questions concerning potential risk applications should be directed to StediChips Co., Ltd.

StediChips semiconductors are typically used in power supplies in which high voltages are present during operation. High-voltage safety precautions should be observed in design and operation to minimize the chance of injury.

Trademark Information

© 2020 StediChips Co., Ltd. All rights reserved. StediChips is the trademark of StediChips Co., Ltd. All other trademarks and registered trademarks are the property of their respective companies.

Contact Information

Web: <http://www.steadichips.com>

E-mail: sales@steadichips.com

Phone: (86) 510-81819665

Fax: (86) 0510-81819676

StediChips Co., Ltd. 1402 Jingyuan International Building A, No. 2 Xiangjiang Road, Wuxi, China 214142